

# User Manual

# SunPhotometer

Version 4.6

***Date impression:***

6 juillet 2001

***Révision:***

REV0

***Référence document:***

Sph/96012\_\_

# PRESENTATION.

The photometer is a portable autonomous instrument. It contains three parts:

- \* a control and measuring unit (the electronic box)
- \* a two axis motorized system
- \* a sensor head

## 1.The electronic box

It contains: - the main CPU card (pilote) for the control and measuring electronics. Its program is loaded in a memory (EPROM) with a label where its name (pilote) and version number are indicated.

- the auxiliary CPU card (automate) which controls the motorized system electronics. Its program is also in an EPROM where the name astp and the version number are indicated.

The two cards are linked via a RS 232 serial junction.

- a screen
- an internal battery.
- panel for cables connectors : motors cables, solar or charger connectors,  
RS232 or DCP connector, head sensor connector, wet sensor connector.

## 2.The motorized system

It carries the optical head, which can rotate around two orthogonal axis ( vertical axis - horizontal axis ).

The positions of the two axis are memorized in the electronic box.

Supply voltage : 5V for the logic, 12V for the motors

## 3.The sensor head

It is the instrument for measuring luminance. It contains:

- two detectors (sky - sun)
- a control and measurement card
- a four quadrant position detector (for a precise tracking on the sun)

- a motorized filter holder wheel with eight filters.
- a temperature sensor.

Supply voltage : 5V for the logic, 12V for the motors

## INSTALLATION PROCEEDINGS.

### 1. Configuring the control and measuring unit.

#### 1.1. Date and time setting (see "Time setting" chapter)

- Enter the date and the T.U. time ( time of the Greenwich meridian, 12 o'clock at noon ).
- Synchronize the system on the reference clock. In order to do this, enter one minute ahead of the actual time and exit the "time setting" function ( by the green key ) rigorously at the exact minute.

#### 1.2. Parametrization.(see "Parametrization" chapter)

- Enter :

SKY/max	NO
SKY Cal	NO
Auto	NO
Auto=>CART	NO Save data in cartridge
Man=>DCP	NO allow transmission of data from manual mode.
DCP Transm YES	active dumping data to the transmitter.
DCP Per 1H	YES For one hour period if transmitting via GOES.
DCP Load T	Time of dumping data to the transmitter.(15 minutes before transmission time).
DCP max	<625 for one minute of METEOSAT or GOES transmission. <1292 for two minutes of METEOSAT or GOES transmission.
T Offset	= 0
Org.offset	= Value indicated on the sensor head, origin of the filter holder wheel (distance in step between the starting plot and the first filter).
Org.H	= +0.0
Org.V	= +0.0
Lat mn	Enter the latitude in minute of arc ( positively towards North )
Lon.HH, Lon.MM, Lon;SS	Enter the longitude in hourly angle (E or W) very precisely (1° <=> 60'). 1 h for 15 ° of arc 4 min for 1° 4 sec for 1' 1 sec for 15".
Fu1 to FA4	Check that all sensibility factors are between 1 and 30 and that the nominal is 5.

## 2. Electrical connection of the motorized system.

Connect to the cable panel :

- Two motors cables of the robot (noted AZ and ZN).
- External battery cable.
- Head sensor cable.
- Wet sensor cable.

## 3. Orientation of the system. Localization of the geographic axis.

The elements of the system are fixed on to a stable and horizontal plane (example: a table) but the sensor head is not engaged into the robot.

- Level the robot with the screws.
- Launch the PARK scenario.

The robot goes to its park position : fix the sensor head as follows :

- the collimator downwards (Nadir).
  - the head sensor connector close to the axis
  - the sensor head windows must be at the same level with V.
  - the head sensor cable can be fixed using the plastic ring and the metallic spring.
- Launch the GOSUN scenario, then adjust the position of the head sensor cable.
  - Direct the robot so that the collimator aims at the sun ( by turning the complete system around the vertical axis).
  - Launch the PARK scenario again.
- Repeat GOSUN scenario for verification.

In the park position the zenithal rotation axis is orientated towards the geographical East-West direction the head sensor must be to West. The head rotation plane is thus the meridian one.

## 4. Installation of the frame.

- Place the tripod so that the solar panel faces towards the South in the northern hemisphere and towards the North in the southern hemisphere.
- After wedging the legs of the tripod, level the photometer support tray by wedging the frame height on to the legs. Block the screws of the three legs after leveling.

## 5. Installation of the photometer motorized system.

- The zenithal and azimuthal orientations must be **rigorous**. ( accuracy of the zenith angle :  $0,25^\circ$  ).
- Introduce the longitude, latitude and date parameters.

## **Azimuth positioning.**

- Launch a PARK scenario.
- Put the motorized system on the frame
- Level the motorized system pedestal.
- Orient the axis of control of the zenithal motor ( vertical movement ) towards the West.
- Launch a GOSUN scenario.
- Direct by hand the motorized system pedestal in azimuth, so that the collimator aims at the sun.\*\*

This operation is correct when the sun image is as close as possible to the aim (white circular target at the collimator).

- Level the motorized system pedestal.
- Check the alignment and correct the orientation of the platform if necessary.
- Block the fixing screws of the pedestal and control again the leveling.
- When everything is fixed check again all preceding wedging.

\*\* Remark : If the pedestal screws holes do not permit the aiming at the sun of the collimator, you have to introduce an offset at the origin.

- Do a GOSUN.
- Go into the motorized system piloting mode, do from the main menu : MAN / SKY / < >. Write down the angles at which the motorized system is.
- Aim at the sun by the manual piloting such as it's image is as close as possible of the aim, and write down the new values of the angles.
- Subtract the two angles of the beginning with the two angles of the end, introduce the calculated offsets in the Org.H and Org.V parameters respectively for the azimuth and zenith angles (see Setup Parameter chapter).
- Do a PARK.
- Do a GOSUN, if the collimator still doesn't aim at the sun, it is because the offsets have been introduced with the wrong sign.

## STARTING UP THE PHOTOMETER.

At the first use, strike any key until this message appears on the screen :

```
** STANDBY **  
awake : red key
```

The station is in standby. Strike the red key to get to the main menu :

```
31 / 12 / 93      23 : 59  
PW MAN SCN VIEW
```

- Abbreviations : [G] for the green key.  
[W] for the white key.  
[Y] for the yellow key.  
[R] for the red key.

**PW** [G]

**Password introduction:**

- Time setting.
- Initialization.
- Setting the constants.
- Setup parameter.

**MAN** [W]

**Access to the manual sequence :**

- With the SUN collimator.
- With the SKY collimator.

**SCN** [Y]

**Access to the programmed scenarios.**

**VIEW** [R]

**Access to the visualization parameters :**

- Of the registered results.
- Of the battery voltage.

Note : After a minute without the keyboard being used, the screen automatically dies away.  
Striking any key makes the main menu appear on the screen.

# PASSWORD INTRODUCTION

## Access to the protected modes.

### PW [G]

Introduce the password : PW = 1  
 [R] to increase.  
 [Y] to decrease.

23 : 59 : 59	PW	0
Pass	Word	- +

A pressure on [W] permits to return to the main menu

31 / 12 / 93	23 : 59
PW MAN SCN VIEW	

Otherwise valid with [G], then the PW menu appears :

23 : 59 : 59
RTN INI DAT PAR

- \*RTN [G] : Return to the main menu.
- \*INI [W] : Memory initialization.
- \*DAT [Y] : Date and time setting.
- \*PAR [R] : Photometer parameters

If the photometer is equipped with a program for DCP VX(1004/2) then you will have this screen

23 : 59 : 59
RTN INI DAT CFG

- \*CFG [R] : Configuration of the photometer and the DCP (VX1004/2).

If you Press CFG [R] you will Get  
 Otherwise valid with [G], then the PW menu appears :

23 : 59 : 59
RTN INFD DCP PAR

- RTN [V] : Return to the main menu.
- INFD [W] : Information about the DCP.
- DCP [Y] : DCP configuration
- PAR [R] : Photometer parameters.

REMARK : The introduction of constants and parameters, and the update of magnitudes are carried out by modifying - increasing or decreasing - the current value.



## TIME SETTING.

The photometer time is the GMT (Greenwich medium time).

**PW / DAT [Y]**

**PW / DAT / - [Y]**

Decreases the values.

**PW / DAT / + [R]**

Increases the values.

**PW / DAT / X [W]**

Presents the following magnitude.

Enter the year.

Year	:	93
OK	X	- +

Enter the month.

Month	:	12
OK	X	- +

Enter the day.

Day	:	31
OK	X	- +

Enter the hour.

Hour	:	23
OK	X	- +

Enter the minute, one unit ahead, as compared to the reference clock.

Minute	:	59
OK	X	- +

**PW / DAT / OK [G]**

Validation and return to the PW menu.

23 : 59 : 59
RTN INI DAT PAR

NOTES : The seconds are implicitly set at zero, this operation must be done exactly when the minutes appear at the reference clock.

Each entrance in the DAT menu, even without any modification, sets the seconds at zero.

## SETUP PARAMETER.

### Constants and system parameters setting.

PW / PAR [R]

Reading EPROM ...
-------------------

Identification of the photometer by its country code.

Country (de 0 à 255)
OK    X    -    +

PW / PAR / - [Y]

Decreases the parameter value.

PW / PAR / + [R]

Increases the parameter value.

PW / PAR / X [W]

Goes to the following parameter.

Identification of the photometer by its district code.

District (de 0 à 9999)
OK    X    -    +

Identification of the photometer by its assigned number.

Number (de 0 à 15)
OK    X    -    +

Selection of the measurement registered in SKY:

SKY/max	YES
OK    X    -    +	

\* YES : highest value on 8 measurements done.

\* NO : last current value.

Permits, by a reduction of gain (10000), the calibration of the SKY canal on the SUN canal.

SKY Cal	NO
OK    X    -    +	

\* YES : low gain for the calibration.

\* NO : high gain for the sky luminance measurement.

\* YES : starts automatically the

Auto	YES
OK    X    -    +	

measurement sequences at the instants fixed by the program and also at those fixed by the user.

\* NO : disactivates the automatic mode.

\* YES : the automatic mode measurements are safeguarded on cartridge.

Auto => CART	NO
OK X -	+

\* NO : the manual measurements only are safeguarded on cartridge.

\* YES : authorizes the DCP to transmit the measurements carried out in manual mode.

Man => DCP	YES
OK X -	+

\* NO : the DCP only transmits the automatic measurements.

Settles the number of characters transmitted by the DCP.

DCP max	100
OK X -	+

\* YES : Active dumping Data from the photometer to the transmitter.

DCP Transm	NO
OK X -	+

\* YES : for 1 hour period of transmission (GOES ).

DCP Per 1 H	YES
OK X -	+

\* NO : for 30 minutes period (METEOSAT).

Time of dumping data to the transmitter (15 minutes before transmission).

DCP Load T	1
OK X -	+

Settles the interval of time between two SUN measurements in the BCLSUN scenario (from 0.5 to 63.5 mn).

BCLSUN mn	1.0
OK X -	+

Compensation of the zero offset of the temperature detector (from -0.8°C to +0.7°C).

T Offset	+0.0
OK X -	+

Origin of the first filter with regard to the starting plot on the filter holder wheel (from 1 to 255 steps).

Org.offset	48
OK X -	+

Permits a precise placing of the filters.

Permits to take into account the possible offset of the azimuthal axis rest position

Org.H	+0.0
OK X -	+

(mechanical origin) in comparison with the geographical marks (see setting up).

Idem for the zenithal axis (in rest position the photometer aims at the ground).

Org.V			+0.0
OK	X	-	+

Latitude of the station in minutes of arc ( $1^\circ \Leftrightarrow 60'$ ).

Ex :  $26^\circ 20'$  must be written  $26 \cdot 60 + 20 = 1580'$ .

Lat mn			+0
OK	X	-	+

Longitude of the station, introduced in hourly angle (HH MM SS), in absolute value with E or W.

Lon.HH		E	0
OK	X	-	+

The longitude is counted positively towards the East, therefore it increases eastward and decreases westward with [R].

$1 \text{ h} \Leftrightarrow 15^\circ \text{ of arc}$      $4 \text{ min} \Leftrightarrow 1^\circ$      $4 \text{ sec} \Leftrightarrow 1'$      $1 \text{ sec} \Leftrightarrow 15''$   
 Ex : longitude =  $30^\circ 32'$   $\Rightarrow$  Lon HH = 2    Lon MM = 2    Lon SS = 8

Longitude in hourly angle : MM.

Lon.MM			0
OK	X	-	+

Longitude in hourly angle : SS.

Lon.SS			0
OK	X	-	+

Sensitivity factor to be applied to the SUN measurements. The canal gain is almost proportional to this factor.  
 to min = 1    max = 30    nominal = 5

Fu1			5
OK	X	-	+

Idem to Fu1 for the other canals.

FO8			5
OK	X	-	+

Sensitivity factor for SKY measurements.  
 Idem to Fu1.

FK1			5
OK	X	-	+

to

FA4			5
OK	X	-	+

Calibration constant for SUN measurements.

Cu1			10000
OK	X	-	+

to

Idem to Cu1 for the other canals.

CO8		10000
OK	X	- +

Calibration constant for SKY  
measurements.  
Idem to Cu1.

CK1		10000
OK	X	- +

to

CA4		10000
OK	X	- +

**PW / PAR / OK** [G]

Validation of the values of the different  
parameters.

Valid ?	
NO	YES

**PW / PAR / OK / NO** [G]

Return to PW menu.

23 : 59 : 59
RTN INI DAT PAR

**PW / PAR / OK / YES** [R]

Safeguard of the parameters in non volatile  
memories.

Writing	EEPROM
---------	--------

Return to PW menu.

23 : 59 : 59
RTN INI DAT PAR

## INITIALIZATION of the buffer.

PW / **INI** [W]

purge memory ?
NO            YES    SBY

PW / INI / **NO** [G]

Return to PW menu :

23 : 59 : 59 RTN INI DAT PAR
---------------------------------

PW / INI / **YES** [Y]

Purge of the memory.

purge success RTN
----------------------

Strike [W], [Y] or [R] to return to  
PW menu.

23 : 59 : 59 RTN INI DAT PAR
---------------------------------

Strike RTN [G] to return to the main  
menu.

31 / 12 / 93            23 : 59 PW MAN SCN VIEW
--

PW / INI / **SBY** [R]

Standby position : then screen becomes blank.

** STANDBY ** awake : red key
----------------------------------

PW / **RTN** [G]

Return to the main menu.

31 / 12 / 93	23 : 59
PW MAN SCN VIEW	

## SCENARIO MODE.

**MAN / SEL** [R]

or **SCN** [Y]

Access to the different scenarios.

hhh : azimuth angle of the motorised system.

vvv : zenith angle of the motorised system.

NAME : scenario name.

<- hhh ->    v    vvv    ^ RTN GO - + NAME
---

**MAN / SEL / - or +** [Y] or [R]

or **SCN / - or +** [Y] or [R]

Scenario selection.

To stop an active the scenario(PC scenario).

<- hhh ->    v    vvv    ^ RTN GO - + OFF
--

To go to the parking position (mechanical origin of the robot).

<- hhh ->    v    vvv    ^ RTN GO - + PARK
---

To aim at the sun (position calculated using SUN equations).

<- hhh ->    v    vvv    ^ RTN GO - + GOSUN
--

Tracking : To adjust the aiming at the sun using othe four quadrants.

<- hhh ->    v    vvv    ^ RTN GO - + TRACK
--

To return to the a = z = 0 position : parking position + or - the org.h and org.v offsets.

<- hhh ->    v    vvv    ^ RTN GO - + ORIGI
--

sun  
Almucantar :azimuthal sweeping with the zenith angle (change of filters).

<- hhh ->    v    vvv    ^ RTN GO - + ALMUC
--

Principal plane : sweeping with a constant azimuth.

<- hhh ->    v    vvv    ^ RTN GO - + PPLAN
--



Measurement of the darkness signal (noise).

```
<- hhh ->   v  vv ^  
RTN GO - + BLACK
```

Measurement of the luminance of the 8 filters with the SUN collimator.

```
<- hhh ->   v  vv ^  
RTN GO - +  SUN
```

Measurement of the luminance of the 4 aerosol filters with the SKY collimator and the same filters with the SUN collimator in high gain.

```
<- hhh ->   v  vv ^  
RTN GO - +  SKY
```

Sun pursuit, tests and focus scenario.

```
<- hhh ->   v  vv ^  
RTN GO - + LTRAK
```

SUN luminance measurement with a pursuit (period set in mn and half mn by the BCLSUN parameter).

```
<- hhh ->   v  vv ^  
RTN GO - + BCLSUN
```

Permanent tracking.

```
<- hhh ->   v  vv ^  
RTN GO - + BCLTRK
```

Polarized principal plane (if equipped polar filter).

```
<- hhh ->   v  vv ^  
RTN GO - +  PPP
```

LANGLEY self calibrating, calculation of the instants for which the sun is seen through determined air masses (it is automatically done at 01:00 and at each change of date, time, longitude or latitude).

```
<- hhh ->   v  vv ^  
RTN GO - + LANGL
```

Initialization of the transmission with a compatible computer.

```
<- hhh ->   v  vv ^  
RTN GO - +  PC
```

SCN / GO [W]

```
activating NAME
```

\* OFF

The screen does not change.

```
<- hhh ->   v  vv ^  
RTN GO - +  OFF
```

\* PARK

```
<- hhh ->   v  vv ^  
01      PARK  ****
```

Then return to the scenario selection screen.

```
<- hhh ->   v  vv ^  
RTN GO - +  PARK
```

\* GOSUN

Then return to the scenario selection screen.

```
<- hhh ->   v  vv ^  
01      GOSUN ****
```

\* TRACK (u1, xxxx, yyyy : cf ALMUC).

A strike on [G], makes you return to the scenario selection screen.

```
<- hhh ->   v  vv ^  
01u1 =     xxxx  yyyy
```

A strike on [W] displays :

```
<- hhh ->   v  vv ^  
RTN   X           v V ^
```

- [W] permits a passage to the azimuth angle (<H>).
- [Y] and [R] permit to decrease and increase the angles values.
- [G] permits to return to the preceding screens.

\* ORIGI

Then return to the scenario selection screen.

```
<- hhh ->   v  vv ^  
01      ORIGI ****
```

\* ALMUC

nn : measurement number.

cc : filter and gain code + filter number :

u <=> sun in low gain, maximal value.

O<=> ozone : sun in high gain, maximal value.

a <=> aureole : sun filter, 2nd measurement; measurement with 1,2,3 and 4 filters.

k <=> measurement with 1,2,3 and 4 filters by the sky detector, 2nd measurement.

x <=> sky collimator, maximal value.

The high gains are in capital letters, not the low gains.

T<=> temperature in the sensor head.

xxxx : - sun : maximum value.

- sky with SKY/max=YES : maximum value.

- sky with SKY/max=NO : value of the preceding measurement.

yyyy : - sun : instantaneous value.

- sky with SKY/max=YES : instantaneous value.

```
<- hhh ->   v  vv ^  
nncc =     xxxx  yyyy
```

- sky with SKY/max=NO : value of the current measurement.

- [Y] permits to stop and start again the scenario.
- [G] permits to return to the scenario selection screen.

\* PPLAN  
Idem to ALMUC.

```
<- hhh ->   v  vv  ^  
ncc =      xxxx  yyyy
```

\* BLACK  
Idem to ALMUC.

```
<- hhh ->   v  vv  ^  
ncc =      xxxx  yyyy
```

Then the screen displays :

```
18T1= 22.0      ****  
Store          Reject
```

A strike on [R] permits to return to the preceding screen without any safeguard of the measurement.

```
<- hhh ->   v  vv  ^  
RTN GO - + BLACK
```

A strike on [G] permits to store the measurement.

```
23 : 59 : 59  
Storing data ...
```

If the storing is on cartridge, you will see this additional screen that winks, and then will return to the scenario selection screen.

```
23 : 59 : 59  
don't touch cart
```

\* SUN  
Idem to BLACK.

```
<- hhh ->   v  vv  ^  
ncc =      xxxx  yyyy
```

```
10T1= 22.0      ****  
Store          Reject
```

\* SKY  
Idem to BLACK.

```
<- hhh ->   v  vv  ^  
ncc=      xxxx  yyyy
```

```
10T1= 22.0      ****  
Store          Reject
```

\* LTRAK

A strike on [G] permits to return to the scenario selection screen.

```
<- hhh ->   v  vv  ^  
01u1=      xxxx  yyyy
```

BCLSUN

```
<- hhh ->   v  vv  ^  
01      BCLSUN  ****
```

Rapid passage on the scenario selection screen.

```
<- hhh ->   v  vv  ^  
RTN GO - + BCLSUN
```

The BCLSUN scenario activates the BCLTRK scenario.

```
activating      BCLTRK
```

```
<- hhh ->   v  vv  ^  
01      BCLTRK  ****
```

Measurements in BCLTRK.

Then return to the scenario selection screen.

```
<- hhh ->   v  vv  ^  
nccc =      xxxx  yyyy
```

\* BCLTRK

Then return to the scenario selection screen.

```
<- hhh ->   v  vv  ^  
01      BCLTRK  ****
```

\* GO&SUN

Idem to GOSUN.

```
<- hhh ->   v  vv  ^  
01      GOSUN   ****
```

Then idem to SUN.

```
<- hhh ->   v  vv  ^  
nccc=      xxxx  yyyy
```

```
10T1= 22.0      ****  
Store          Reject
```

\* LANGL

Then return to the scenario selection screen.

```
<- hhh ->   v  vv  ^  
01      LANGL   ****
```

\* PC

The XXXX numbers decrease until 0000, it represents the transference of memory in a file.

Then the screen displays the scenario selection menu.

PC :	XXXX	0000
31 / 12		23 : 59 : 59

<- hhh ->	v	vvv	^
RTN	GO	- +	PC

MAN / SEL / GO [W]

```
activating
NAME
```

\* OFF

Return to the MAN menu.

```
31 / 12 / 93      23 : 59
RTN SUN SKY SEL
```

\* PARK

A strike on NEXT [R] does not do anything.

```
01      PARK      ****
ABO < > RUN NEXT
```

A strike on ABO [G] makes you return to the MAN menu.

```
31 / 12 / 93      23 : 59
RTN SUN SKY SEL
```

A strike on RUN [Y] displays :

```
01      PARK      ****
ABORT      autorecord
```

A strike on ABORT [G], makes you return directly to the MAN menu.

```
31 / 12 / 93      23 : 59
RTN SUN SKY SEL
```

A strike on [Y], makes you return to the preceding screen.

```
01      PARK      ****
ABO < > RUN NEXT
```

A strike on < > [W] displays :

[W] permits a passage to the azimuth angle (<H>).

[Y] and [R] permit to decrease and increase the angles values.

A strike on RTN [V] permits to return to the preceding screen.

```
<- hhh ->      v  vvv  ^
RTN  X          v  V  ^
```

```
01      PARK      ****
ABO < > RUN NEXT
```

If you don't strike any key, the PARK scenario takes place normally, at the end it returns to the MAN menu.

```
31 / 12 / 93      23 : 59
RTN SUN SKY SEL
```

\* GOSUN  
Idem to PARK.

```
01      GOSUN      ****  
ABO < > RUN NEXT
```

\* TRACK  
Search of the starting plot.

```
          Searching  
starting      plot  ...
```

Idem to PARK.

```
01u1 =      xxxx   yyyy  
ABO < > RUN NEXT
```

\* ORIGI  
Idem to PARK.

```
01      PARK      ****  
ABO < > RUN NEXT
```

\* ALMUC  
Idem to PARK except that NEXT [R] permits a passage to the following measurement. RUN [Y] permits to the measurements to be automatic; a strike on [Y] permits to return to the preceding screen and the measurements can be done one by one.  
At end of the measurements the screen displays :

```
nncc =      xxxx   yyyy  
ABO < > RUN NEXT
```

```
78T4 = 22.0      ****  
Store                Reject
```

A strike on [R] permits to return to the MAN menu without safeguarding the measurements.

```
31 / 12 / 93      23 : 59  
RTN SUN SKY SEL
```

A strike on [G] permits to store the measurements.

```
23 : 59 : 59  
Storing data ...
```

If the storing is on cartridge, you will see this additional screen that winks.

```
23 : 59 : 59  
don't touch cart
```

```
78T4 = 22.0      ****  
ABORT            autorecord
```

Then you return to the MAN menu.

```
31 / 12 / 93      23 : 59  
RTN SUN SKY SEL
```

\* PPLAN  
Idem to ALMUC.

```
nnc =      xxxx  yyyy  
ABO < > RUN NEXT
```

```
42T4 = 22.0      ****  
Store              Reject
```

\* BLACK  
Search of the starting plot.

```
Searching  
starting      plot  ...
```

Idem to ALMUC.

```
nnc =      xxxx  yyyy  
ABO < > RUN NEXT
```

```
18T1 = 22.0      ****  
Store              Reject
```

\* SUN  
Idem to ALMUC.

```
nnc =      xxxx  yyyy  
ABO < > RUN NEXT
```

```
10T1 = 22.0      ****  
Store              Reject
```

\* SKY  
Idem to ALMUC.

```
nnc =      xxxx  yyyy  
ABO < > RUN NEXT
```

```
10T1 = 22.0      ****  
Store              Reject
```

\* LTRAK  
Idem to ALMUC.

```
01u1      xxxx  yyyy  
ABO < > RUN NEXT
```



\* BCLSUN

```
01   BCLSUN   ****  
ABO < > RUN NEXT
```

Rapid passage on the MAN menu.

```
31 / 12 / 93      23 : 59  
RTN SUN SKY SEL
```

The BCLSUN scenario activates the BCLTRK scenario.

```
activating      BCLTRK
```

This screen appears a few seconds.

```
<- hhh ->      v vvv ^  
RTN GO - + BCLSUN
```

The BCLTRK scenario makes some measures :

```
<- hhh ->      v vvv ^  
01u1 =      xxxx  yyyy
```

Then return to the scenario selection screen.

```
<- hhh ->      v vvv ^  
RTN GO - + BCLSUN
```

\* BCLTRK

```
<- hhh ->      v vvv ^  
01   BCLTRK   ****
```

Return to the scenario selection screen.

```
<- hhh ->      v vvv ^  
RTN GO - + BCLTRK
```

\* GO&SUN

This scenario activates the GOSUN scenario.

```
01   GOSUN   ****  
ABO < > RUN NEXT
```

Idem to ALMUC.

```
ncc =      xxxx  yyyy  
ABO < > RUN NEXT
```

```
10T1 = 22.0      ****  
Store           Reject
```

A strike on Reject [R] permits to return to the MAN menu without safeguarding the

```
31 / 12 / 93      23 : 59  
RTN SUN SKY SEL
```

measurements.

A strike on Store [G] permits to store the measurements :

```
23 : 59 : 59
Storing data ...
```

Then the scenario launches an ORIGI scenario :

```
10   ORIGI   ****
ABORT   autorecord
```

And finally returns to the MAN menu.

```
31 / 12 / 93   23 : 59
RTN SUN SKY SEL
```

\* LANGL

```
01   LANGL   ****
ABO < > RUN NEXT
```

Return to the MAN menu.

```
31 / 12 / 93   23 : 59
RTN SUN SKY SEL
```

\* PC

The XXXX numbers decrease until 0000, it represents the transference of memory in a file.

```
PC :   XXXX 0000
31 / 12   23 : 59 : 59
```

Then the screen displays the scenario selection menu.

```
<- hhh ->   v   vvv ^
RTN GO - +   PC
```

**MEASUREMENT OF  
RADIANCE AND IRRADIANCE  
in manual mode.**

**MAN** [W]

31 / 12 / 93      23 : 59  
RTN SUN SKY SEL

**MAN / SUN** [W]

Measurement sequence with SUN collimator.

**MAN / SKY** [Y]

Measurement sequence with SKY collimator.

Search of the starting plot : reference position  
of the filter holder wheel.

Searching  
starting plot ...

\* If the starting plot is not found (connection  
problem), the screen displays :

error at  
starting plot

Strike any key to return to the MAN  
menu :

31 / 12 / 93      23 : 59  
RTN SUN SKY SEL

\* If the starting plot is found, the first filter is  
ready for the measurements.

ncc =      xxxx    yyyy  
ABO < > RUN NEXT

The system memorizes :

in SUN the maximal value

in SKY the value of the last measurement

(ncc, xxxx, yyyy : see chapter "Scenario mode", paragraph SCN / GO \*ALMUC)

**MAN / SUN / ABO** [G]

or **MAN / SKY / ABO** [G]

Abortion of the sequence.

Return to the MAN menu.

31 / 12 / 93      23 : 59  
RTN SUN SKY SEL

MAN / SUN / **NEXT** [R]  
or MAN / SKY / **NEXT** [R]

Selection filter after filter.

Increases the filter's number and makes a measurement with this new filter.

```
ncc =      xxxx  yyyy  
ABO < > RUN NEXT
```

MAN / SUN / **RUN** [Y]  
or MAN / SKY / **RUN** [Y]

launch of an automatic measurement cycle (all the filters).

```
ncc =      xxxx  
yyyy  
ABORT      autorecord
```

\* A strike on ABORT [G], makes you return to the MAN menu.

```
31 / 12 / 93      23 : 59  
RTN SUN SKY SEL
```

\* A strike on [Y], makes you return to the preceding screen :

```
ncc =      xxxx  yyyy  
ABO < > RUN NEXT
```

\* Otherwise the filters automatically defile (8 measures). You can choose to store or reject the measurements.

```
10T1 = 22.0      ****  
Store            Reject
```

MAN / SUN / RUN / **STORE** [G]  
or MAN / SKY / RUN / **STORE** [G]

Storing of the last measurements.

Storing.

```
23 : 59 : 59  
Storing  data  ...
```

If the storing is on cartridge, you will see this additional screen that winks

```
23 : 59 : 59
Storing data ...
```

Return to the MAN menu.

```
31 / 12 / 93
RTN SUN SKY SEL
```

MAN / SUN / RUN / **REJECT** [R]  
or MAN / SKY / RUN / **REJECT** [R]  
Reject of the last measurements.

Return to the MAN menu.

```
31 / 12 / 93
RTN SUN SKY SEL
```

MAN / SUN / < > [W]

Piloting of the motorized system.

hhh : azimuth angle of the motorized system.  
vvv : zenith angle of the motorized system.

```
<- hhh -> v vvv ^
RTN X v V ^
```

- [W] permits a passage to the azimuth angle < H >, you will then be able to change it's value.
- [Y] and [R] permit to decrease and increase the angles' values.
- [G] permits to return to the MAN menu.

```
31 / 12 / 93 23 : 59
RTN SUN SKY SEL
```

MAN / **RTN** [G]

Return to the main menu.

```
31 / 12 / 93 23 : 59
PW MAN SCN VIEW
```

# DESCRIPTION OF THE SKY RADIANCE MEASUREMENTS PROCEEDINGS ( Scenarios ALMU, PPLAN and PPP)

## 1. ALMUCANTAR :

The Almucantar technique consists of measuring the sky radiance in aerosol channels, in the azimuth plane with a zenith angle of view equal to the zenith solar angle ( $\theta_s = \theta_v$ ). The particular geometry where we measure direct solar irradiance is not part of the data set. The step in azimuth  $\Delta\Phi$  vary with the value of  $(\phi_s - \phi_v)$ . It is smaller when  $\phi_s - \phi_v$  is  $< 20^\circ$  to  $0^\circ$ , and incrementally larger as  $\phi_s - \phi_v$  approaches  $180^\circ$ . The viewing sequences is as follows :

Value of the maximum of 8 measurements in low gain with the SUN collimator at the position  $0.0^\circ$  ( sun alignment) then

Value of the second measurement in high gain with the using sun collimator (aureole) at the following positions :  $\phi_s - \phi_v =$

$-6.0^\circ$	$-5.0^\circ$	$-4.0^\circ$	
$-3.5^\circ$	$-3.0^\circ$	$-2.5^\circ$	$-2.0^\circ$
$2.0^\circ$	$2.5^\circ$	$3.0^\circ$	$3.5^\circ$
$4.0^\circ$	$5.0^\circ$	$6.0^\circ$	

Measurements in high gain with the sky collimator at the following positions:

	$6.0^\circ$	$7.0^\circ$	$8.0^\circ$		
	$10.0^\circ$	$12.0^\circ$	$14.0^\circ$	$16.0^\circ$	$18.0^\circ$
$20.0^\circ$					
	$25.0^\circ$	$30.0^\circ$	$35.0^\circ$	$40.0^\circ$	$45.0^\circ$
$50.0^\circ$					
	$60.0^\circ$	$70.0^\circ$	$80.0^\circ$	$90.0^\circ$	$100.0^\circ$
	$120.0^\circ$	$140.0^\circ$	$160.0^\circ$		
	$180.0^\circ$				
	$200.0^\circ$	$220.0^\circ$	$240.0^\circ$		
	$260.0^\circ$	$270.0^\circ$	$280.0^\circ$	$290.0^\circ$	$300.0^\circ$
	$310.0^\circ$	$315.0^\circ$	$320.0^\circ$	$325.0^\circ$	$330.0^\circ$
$335.0^\circ$					
	$340.0^\circ$	$342.0^\circ$	$344.0^\circ$	$346.0^\circ$	$348.0^\circ$
$350.0^\circ$					
	$352.0^\circ$	$353.0^\circ$	$354.0^\circ$		

Measurements in high gain with the SUN collimator (aureole) :

354.0°	355.0°	356.0°	
356.5°	357.0°	357.5°	358.0°
362.0°	362.5°	363.0°	363.5°
364.0°	365.0°	366.0°	

The sequence begin by aligning on the sun, to 6° and sweep through the sun in the above stated increments. Upon completion change filter, align on the sun begin a new sequence.

## 2. PRINCIPAL PLANE :

The sky radiance in the aerosol channels is also measured in the principal plane, that is the zenith angle will change while the azimuth angle is constant. relative to the sun position data will be collected according to the following angles :

Measurements in high gain with the SUN collimator (aureole) :

-6.0°	-5.0°	-4.0°		
-3.5°	-3.0°	-2.5°	-2.0°	0°
2.0°	2.5°	3.0°	3.5°	
4.0°	5.0°	6.0°		

Measurements in high gain with the sky collimator

	6.0°	8.0°	10.0°	12.0°	14°	
16.0°	20.0°	25.0°	30.0°	35.0°	40.0°	45°
	50.0°	55.0°	60.0°	65.0°	70.0°	
80.0°	90.0°	100.0°	110.0°	120.0°	130.0°	
140.0°	150.0°					

The sequence begin by aligning on the sun, to -6° and sweep through the sun in the above stated increments. Upon completion change filter, align on the sun begin a new sequence

## 3. PPP (Polarized Principal Plan) :

Only one scan is realized from +95° to +265°, by step of 5°. At each position three measurements are made one at each polarized filter (870 nm).

## AUTOMATIC MODE.

Measurements with a calibrated instrument of direct solar irradiance and Sky radiance can be used to

- derive atmosphere optical thickness at 5 wavelengths and water vapor and ozone content (from differential gaseous absorption approach).
- Aerosol distributions.
- Langley Plot : automatic measurements allows measurements of direct solar irradiance at different air masses. Assuming aerosol optical thickness is the same for each air mass, the linear regression of the logarithm of measurement voltages versus air mass gives as a intercept the logarithm of exo-atmospheric voltage and as slope total optical thickness.

The photometer has some actions, pre-programmed, that start successively at some pre-defined times in automatic mode : Automatic actions.

Moreover the user can program himself some actions that will carry out automatically : user actions.

In the following list of Automatic actions there will be indicated whether the time or the air mass for which the sequences (Group of actions) will be realized.

In the case of air masses, the starting times (Langley times) are calculated for each photometer by the LANGL scenario, these times are different according to its site.

The time of LANGL scenario is automatically calculated at 01:00 and at each change of date, time and any other parameters for more security. It can also be done in so far as a scenario by the user.

### List of the Automatic Sequences :

Sequences	CODE	Type of Photometer	Definition
GROUP A	17	NORMAL and POLAR	3 SUN; 3 SKY
GROUP B	18	NORMAL and POLAR	3 SUN; 3 SKY; ALMU; BLACK
GROUP C	19	NORMAL	3 SUN; 3 SKY; ALMU; PP BLACK
GROUP C	19	POLAR	3 SUN; 3 SKY; ALMU; PP; PPP; BLACK
GROUP D	20	NORMAL and POLAR	3 SUN;
GROUP E	21	NORMAL and POLAR	3 SUN; PP
GROUP E	21	POLAR	3 SUN; PP; PPP
GROUP F	22	NORMAL	3 SUN; ALMU; PP; BLACK
GROUP F	22	POLAR	3 SUN; ALMU; PP; PPP; BLACK



This mode allows automatic measurements of solar irradiance and sky radiance at different air masses (from 7 to 1.7) and some other programmable times from sunrise to sunset.

## 1. List of the Automatic actions :

<b>Air masses</b>	<b>Actions</b>
7.0	GROUPA
6.5	GROUPA
6.0	GROUPA
5.5	GROUPA
5.0	GROUPA
4.5	GROUPA
4.0	GROUPB
3.8	GROUPA
3.6	GROUPA
3.4	GROUPA
3.2	GROUPA
3.0	GROUPC
2.8	GROUPA
2.6	GROUPA
2.4	GROUPA
2.2	GROUPA
2.0	GROUPB
1.7	GROUPB

<b>Time</b>	<b>Actions</b>
07h30	GROUPD
07h45	GROUPD
08h00	GROUPE
08h15	GROUPD
08h30	GROUPD
08h45	GROUPD
09h00	GROUPE
09h15	GROUPD
09h30	GROUPD
09h45	GROUPD
10h00	GROUPE
10h15	GROUPD
10h30	GROUPD
10h45	GROUPD
11h00	GROUPE
11h15	GROUPD
11h30	GROUPD
11h45	GROUPD
12h00	GROUPE

If air mass =2 is obtained before 7h30 actions from 7h30 up to 8h45 will be made. actions beginning at 9h will have the priority, all air mass obtained after 9h will be canceled.

Extra almucantars will be made relative to air masses 4, 3, 2, and 1.7

If the photometer is able to make measurements at these air masses (before 9h) this will modify the number of extra almucantars as follows :

If measurements are possible at :

Air masses	Extra ALM will be done at
4 3 2 1.7	10h 11h
4 3 2	9h 10h 11h
4 3	9h 10h 11h 12h
4	9h 10h 11h 12h

If these air masses obtained after 9h (so will be canceled) there will be extra ALM at 9h 10h 11h 12h.

### **Polar Photometer**

If measurements are possible at these air masses then extra ALM will be made at

4 3 2 1.7	10h 11h
4 3 2	9h 10h
4 3	9h 10h 11h
4	9h 10h 11h 12h

If these air masses obtained after 9h (so will be canceled) there will be extra ALM at 9h 10h 11h 12h

## **2. Visualization of the actions starting times.**

The times of starting of the automatic actions can be visualized by doing PW = 2

Select PW in the main menu.

Introduce PW = 2 with [R] and valid with [G].

\*Y : - if the photometer is in manual mode Y = n.  
- if the photometer is in automatic mode Y = N.

This screen appears for a few seconds.

31 / 12 / 93	23 : 59
PW MAN SCN VIEW	

\*HH : MM : SS: clock.

\*hh : mm : ss: time of the action starting.

\*XX: action number :

- user action from 1 to 26.

- Langley actions on and over 27.

23 : 59 : 59	PW	0
Pass	Word	- +

LANGL	HH : MM : SS
XX => 255	FF : FF : FF

\*aa : number of the next user action to execute.  
\*bb : number of the next Langley action to execute.  
\*uuu : code of the sequence to execute  
:

Y : aa / bb	HH : MM : SS
XX => uuu	hh : mm : ss

Press on [W] to modify the action that is displayed :

The cursor appears under the value to modify.  
[W] permits to move the cursor.  
[Y] and [R] permit to decrease and increase the values.

Y : aa / bb	HH : MM : SS
XX => uuu	<u>h</u> h : mm : ss

[G] validates the modifications and permits to exit this mode.

Y : aa / bb	HH : MM : SS
XX => uuu	hh : mm : ss

Strikes on [Y] or [R] permit to display respectively the preceding or following actions..

A strike on [G] permits to return to the main menu.

31 / 12 / 93	23 : 59
PW	MAN SCN VIEW

Remarks : The actions programmed by the user have to be classified in the hourly order.  
The actions are executed at the hh : mm : ss time exactly.  
If several user actions are programmed at the same time, the actions will be executed (if the photometer is in automatic mode) in the order of their scenario or sequence code.

## CONSULTATION.

### VIEW [R]

31 / 12 / 93	23 : 59		
RTN	BAT	CART	MEM

### VIEW / BAT [W]

Consultation of different parameters.

Instantaneous value of the internal battery's voltage. In order to have access to the following parameter use [R]. [Y] will make you go back to the preceding menu.

23 : 59 : 59	Ba	5.20
--------------	----	------

Instantaneous value of the photometer's detectors' temperature.

23 : 59 : 59	T	22.0
--------------	---	------

Instantaneous value of the humidity.

23 : 59 : 59	HH	0
--------------	----	---

Instantaneous value of the SKY measurement.

23 : 59 : 59	SK	0
--------------	----	---

Instantaneous value of the SUN measurement.

23 : 59 : 59	SN	0
--------------	----	---

A strike on [G] permits a return to the main menu

31 / 12 / 93	23 : 59		
PW	MAN	SCN	VIEW

The measurements are stocked in a buffer before being transferred to the cartridge and this at the end of the tenth bloc, or at midnight, even if the measurements in the buffer occupy less than ten blocs (a data bloc = 256 bytes).

**VIEW / MEM [R]** Consultation of the measurements saved in the buffer.

\*XX : scenario or sequence code (see list at the end of this paragraph).

XX	Y	31 ->	12	23 : 59
NN/MM		cc		yyyy

\*Y : defines the mode :

- M : measurement safeguarded in memory done in automatic mode.

- m : measurement safeguarded in memory done in manual mode.

\*NN/MM : number of the measurement/number total of measurements.

\*cc : code of the filter on which the measurement has been done (see list in the Scenario mode chapter, at the SCN/GO \*ALMUC paragraph).

\*yyyy : value of the measurement.

- [Y] permits the consultation of the preceding measurement.

- [R] permits the consultation of the following measurement.

- [W] permits the scrolling of the data bloc.

31 / 12 / 93	23 : 59
PW MAN SCN VIEW	

- [G] permits to return to the main menu.

List of the scenarios codes :

00	OFF
01	PARK
02	GOSUN
03	TRACK
04	ORIGI
05	ALMUC
06	PPLAN
07	BLACK
08	SUN
09	SKY
10	LTRAK
11	BCLSUN
12	BCLTRK
13	GO&SUN
14	LANGL
15	PC

**VIEW / CART [Y]**

Consultation of the measurements saved in the cartridge.

Reading of the cartridge.

reading cart ...

\* If the cartridge is not connected, the screen displays :

cart : none

Then strike any key to get back to the VIEW menu.

31 / 12 / 93      23 : 59  
RTN BAT CART MEM

\* Otherwise : - If the cartridge is empty the screen will display this :

cart : fresh

- If the cartridge has some measurements in memory, xxx represents the number of blank pages left.

cart : xxx/127

Striking any key permits to consult the measurements safeguarded on cartridge. The same screen as for VIEW / MEM is displayed.

The only difference will be that Y will be whether K, or k :

- K : measurement safeguarded on cartridge effected in automatic mode.
- k : measurement safeguarded on cartridge effected in manual mode.

**VIEW / RTN [G]**

Return to the main menu.

31 / 12 / 93      23 : 59  
PW MAN SCN VIEW

## PROCEDURE OF TOTAL ERASING of the context and the data.

**WARNING ! Use this only if the photometer refuses to work correctly.  
All the data are definitely lost.**

31 / 12 / 93	23 : 59
PW MAN SCN VIEW	

**PW [G]**

23 : 59 : 59	PW 0
Pass Word	- +

Choose PW = 1 and return to the main menu :

Strike [G] second time.

Choose again PW [G] and PW = 3 (strike [R] 3 times).

31 / 12 / 93	23 : 59
PW MAN SCN VIEW	

Strike [W] once.

23 : 59 : 59	PW 3
Pass Word	- +

Strike [W] a second time.

Menu Lecture
RTN FLG K7 RAM

Strike [R] once.

31 / 12	23 : 59 : 59
RTN MON MAT TST	

Strike [W] once.

0003 : 20 00 86	02
RTN Mod	- +

Strike [R] once, then you are in test mode = 01.

0003 : 20 => 00	
RTN Ecr	- +

Strike [G] once.

0003 : 20 => 01	
RTN Ecr	- +



```
0003 : 20 00 86      02
RTN  Mod  -      +
```

You return in normal mode by striking [Y]  
=> 00

Then a third, the screen is disactivated.

Strike then any key to return to the main menu.

```
31 / 12/93      23 : 59 :59
RTN  MON MAT TST
```

Choose PW [G].

Enter PW = 1 and validate with [G], then you have the PW menu.

```
31 / 12 / 93      23 : 59
PW  MAN SCN VIEW
```

Choose INI [W].

```
23 : 59 : 59      PW  0
Pass  Word        -      +
```

Strike [W], the screen dies away, the clock is set at zero.

```
23 : 59 : 59
RTN  INI DAT PAR
```

In order to exit the test mode you have to return to the main menu.

```
purge  memory  ?
NO      YES    SBY
```

Choose PW [G].

```
purge  success
RTN
```

Enter PW = 3 (strike [R] 3 times).

```
31 / 12 / 93      23 : 59
PW  MAN SCN VIEW
```

Strike [W] once.

```
23 : 59 : 59      PW  0
Pass  Word        -      +
```

Then a second time.

```
23 : 59 : 59      PW  3
Pass  Word        -      +
```

Strike [R].

```
Menu  Lecture
RTN  FLG K7 RAM
```

And then again [W].

```
31 / 12      23 : 59 : 59
RTN  MON MAT TST
```

```
0003 : 20 00 86      02
RTN  Mod  -      +
```

0003 : 20 => 01
RTN Ecr - +

0003 : 20 => 00
RTN Ecr - +

Strike [G].

Then a second time.

0003 : 20 => 00
RTN Ecr - +

The third time disactive the screen.

Then strike [G].

0003 : 20	00	86	02
RTN	Mod	-	+

Strike any key to eturne again to the main menu.

31 / 12	23 : 59 : 59
RTN	MON MAT TST

Strike then any key to return to the main menu.

--

31 / 12 / 93	23 : 59
PW	MAN SCN VIEW

## Annex 1

### Photometer (CE 318-1)

Information about Manual and Automatic Scenarios :

Positions (angles), Filter and the corresponding Symbol's at Display.

The following table present the Gain parameters and the its related filters :

Gain parameters	Filters
Fu1 (SUN measurements )	1020 nm
Fu2 (SUN measurements )	870 nm
Fu3 (SUN measurements )	670 nm
Fu4 (SUN measurements )	440 nm
Fu5 (SUN measurements )	940 nm Optional (black if absent)
Fu6 (SUN measurements )	936 nm
FO7 (SUN measurements )	Ozone Optional (black if absent)
FO8 (SUN measurements )	Ozone Optional (black if absent)
FK1 (SKY measurements)	1020 nm
FK2 (SKY measurements)	870 nm
FK3 (SKY measurements)	670 nm
FK4 (SKY measurements)	440 nm
FA1 (SKY measurements using sun collimator)	1020 nm
FA2 (SKY measurements using sun collimator)	870 nm
FA3 (SKY measurements using sun collimator)	670 nm
FA4 (SKY measurements using sun collimator)	440 nm

When transferring data from the photometer to PC the number of filter is given with respect to its position in the filter wheel : the following table gives the order of the filters in the filter wheel :

Filter number	Filter
1	1020 nm
2	870 nm
3	670 nm
4	440 nm
5	940 nm
6	936 nm
7	Ozone
8	Ozone

From the parameters of the photometer (PAR)

SKY/max                    yes or no

    If Yes                    MV: Maximum value (measure)  
    if NO                    LV: Last value(measure),

SKY Cal                    yes or no

    If Yes                    LG : low gain  
    If No                    HG : High gain

Symbol will be displayed in relation to your choice and depending on the type of measurements SUN or SKY:

### **SKY Measurements :**

Measurements from 1 to 4 ( 1020, 870, 660,440) are made using Sun collimator, from 5 to 11 using Sky collimator.

Number	Filter	SKY-HG-MV	SKY HG LV	SKY-LG-MV	SKY-LG-LV
1	1020	A1	A1	A1	A1
2	870	A3	A2	A3	A2
3	670	A4	A3	A4	A3
4	440	A2	A4	A2	A4
5	1020	X1	K1	x1	k1
6	870	X2	K1	x1	k2
7	670	X3	K3	x3	k3
8	440	X4	K4	x4	k4

### SUN Measurements :

Filter number	filter	SUN
1	1020	u1
2	870	u2
3	670	u3
4	440	u4
5	940	u5
6	936	u6
7	Ozone	O7
8	Ozone	O3

### PPLAN :

Scanning the vertical plan relative to the zenithal position of the sun.

Position (N-measure)	Display(first scan)	2 scan	3 scan	4 scan
-6° to -2° (1 to 7)	A1	A2	A3	A4
0° (8)	u1	u2	u3	u4
+2° to+6° (9-15)	A1	A2	A3	A4
6° to 150°(16 -40)	K1	K2	K3	K4

u : indicates to measurement made using Sun collimator at low gain  
u1 = 1020, u2 = 870nm , u3 = 670nm, u4 = 440nm.

A : indicates to measurement made using Sun collimator at high gain  
A1 = 1020, A2 = 870nm, A3 = 670nm, A4 = 440nm.

K : indicates to measurement made using Sky collimator at high gain  
K1 = 1020, K2 = 870nm, K3 = 670nm, K4 = 440nm.

The following Table represents for a principal plane scenario the relative number of measurements, positions, and symbol of each measurement.

**(at the position 6° two measurements are made)**

Number	Position	1 Scan	2 Scan	3 Scan	4 Scan
1	-6.0	A1	A2	A3	A4
2	-5.0	A1	A2	A3	A4
3	-4.0	A1	A2	A3	A4
4	-3.5	A1	A2	A3	A4
5	-3.0	A1	A2	A3	A4
6	-2.5	A1	A2	A3	A4
7	-2.0	A1	A2	A3	A4
8	0	u1	u2	u3	u4
9	+2.0	A1	A2	A3	A4
10	+2.5	A1	A2	A3	A4
11	+3.0	A1	A2	A3	A4
12	+3.5	A1	A2	A3	A4
13	+4.0	A1	A2	A3	A4
14	+5.0	A1	A2	A3	A4
<b>15, 16</b>	<b>+6.0</b>	<b>A1,K1</b>	<b>A2,K2</b>	<b>A3,K3</b>	<b>A4,K4</b>
17	+8.0	K1	K2	K3	K4
18	+10.0	K1	K2	K3	K4
19	+12.0	K1	K2	K3	K4
20	+14.0	K1	K2	K3	K4
21	+16.0	K1	K2	K3	K4
22	+20.0	K1	K2	K3	K4
23	+25.0	K1	K2	K3	K4
24	+30.0	K1	K2	K3	K4
25	+35.0	K1	K2	K3	K4
26	+40.0	K1	K2	K3	K4
27	+45.0	K1	K2	K3	K4
28	+50.0	K1	K2	K3	K4
29	+55.0	K1	K2	K3	K4
30	+60.0	K1	K2	K3	K4
31	+65.0	K1	K2	K3	K4
32	+70.0	K1	K2	K3	K4
33	+80.0	K1	K2	K3	K4
34	+90.0	K1	K2	K3	K4
35	+100.0	K1	K2	K3	K4
36	+110.0	K1	K2	K3	K4
37	+120.0	K1	K2	K3	K4
38	+130.0	K1	K2	K3	K4
39	+140.0	K1	K2	K3	K4
40	+150.0	K1	K2	K3	K4
41	Temperature	T	T	T	T

## **ALMUCANTAR :**

Scanning the horizontal plane relative to the azimuth position of the sun.

a : indicates to measurement made using Sun collimator at low gain

u1 = 1020, u2 = 870nm , u3 = 670nm, u4 = 440nm.

A : indicates to measurement made using Sun collimator at high gain

A1 = 1020, A2 = 870nm, A3 = 670nm, A4 = 440nm.

K : indicates to measurement made using Sky collimator at high gain

K1 = 1020, K2 = 870nm, K3 = 670nm, K4 = 440nm.

Position (N-measure)	TYPE	Display(first scan)	2 scan	3 scan	4 scan
0° (1)	SUN-LG	u1	u2	u3	u4
-6° to +6° (2-15)	SUN-HG	A1	A2	A3	A4
+6° to 254°(16-62)	SKY-HG-LV	K1	K2	K3	K4
254°to266°(62-76)	SUN-HG	A1	A2	A3	A4

(at each of the positions 6° and 254 ° two measurements are made one in SUN- HG and the other SKY - HG)

Number	POSITION °	1 SCAN	2 SCAN	3SCAN	4 SCAN
		1020 nm	870 nm	670 nm	440 nm
1	0.0	u1	u2	u3	u4
2	-6.0	A1	A2	A3	A4
3	-5.0	A1	A2	A3	A4
4	-4.0	A1	A2	A3	A4
5	-3.5	A1	A2	A3	A4
6	-3.0	A1	A2	A3	A4
7	-2.5	A1	A2	A3	A4
8	-2.0	A1	A2	A3	A4
9	+2.0	A1	A2	A3	A4
10	+2.5	A1	A2	A3	A4
11	+3.0	A1	A2	A3	A4
12	+3.5	A1	A2	A3	A4
12	+4.0	A1	A2	A3	A4
14	+5.0	A1	A2	A3	A4
<b>15, 16</b>	<b>+6.0</b>	<b>A1, K1</b>	<b>A2, K2</b>	<b>A3, K3</b>	<b>A4, K4</b>
17	+7.0	K1	K2	K3	K4
18	+8.0	K1	K2	K3	K4
19	+10.0	K1	K2	K3	K4
20	+12.0	K1	K2	K3	K4
21	+14.0	K1	K2	K3	K4
22	+16.0	K1	K2	K3	K4
23	+18.0	K1	K2	K3	K4
24	+20.0	K1	K2	K3	K4
25	+25.0	K1	K2	K3	K4
26	+30.0	K1	K2	K3	K4
27	+35.0	K1	K2	K3	K4
28	+40.0	K1	K2	K3	K4
29	+45.0	K1	K2	K3	K4
30	+50.0	K1	K2	K3	K4
31	+60.0	K1	K2	K3	K4
32	+70.0	K1	K2	K3	K4
32	+80.0	K1	K2	K3	K4
34	+90.0	K1	K2	K3	K4
35	+100.0	K1	K2	K3	K4
36	+120.0	K1	K2	K3	K4
37	+140.0	K1	K2	K3	K4
38	+160.0	K1	K2	K3	K4
39	+180.0	K1	K2	K3	K4
40	+200.0	K1	K2	K3	K4
41	+220.0	K1	K2	K3	K4
42	+240.0	K1	K2	K3	K4
43	+260.0	K1	K2	K3	K4
44	+270.0	K1	K2	K3	K4
45	+280.0	K1	K2	K3	K4
46	+290.0	K1	K2	K3	K4
47	+300.0	K1	K2	K3	K4
48	+310.0	K1	K2	K3	K4
49	+315.0	K1	K2	K3	K4



50	+320.0	K1	K2	K3	K4
51	+325.0	K1	K2	K3	K4
52	+320.0	K1	K2	K3	K4
53	+325.0	K1	K2	K3	K4
54	+340.0	K1	K2	K3	K4
55	+342.0	K1	K2	K3	K4
56	+344.0	K1	K2	K3	K4
57	+346.0	K1	K2	K3	K4
58	+348.0	K1	K2	K3	K4
59	+350.0	K1	K2	K3	K4
60	+352.0	K1	K2	K3	K4
61	+353.0	K1	K2	K3	K4
<b>62, 63</b>	<b>+354.0</b>	<b>K1, A1</b>	<b>K2, A2</b>	<b>K3, A3</b>	<b>K4, A4</b>
64	+355.0	A1	A2	A3	A4
65	+356.0	A1	A2	A3	A4
66	+356.5	A1	A2	A3	A4
67	+357.0	A1	A2	A3	A4
68	+357.5	A1	A2	A3	A4
69	+358.0	A1	A2	A3	A4
70	+362.0	A1	A2	A3	A4
71	+362.5	A1	A2	A3	A4
72	+363.0	A1	A2	A3	A4
73	+363.5	A1	A2	A3	A4
74	+364.0	A1	A2	A3	A4
75	+365.0	A1	A2	A3	A4
76	+366.0	A1	A2	A3	A4
77	Temperature	T	T	T	T

## Annex 2

### Photometer (CE 318-2) polarized version

Information about Manual and Automatic Scenarios. Positions (angles), Filter and the corresponding Symbol's for Display.

The following table present the Gain parameters and the its related filters :

Gain parameters	Filters
Fu1 (SUN measurements )	1020 nm
Fu2 (SUN measurements )	870 nm, and the three polarized 870 nm
Fu3 (SUN measurements )	670 nm
Fu4 (SUN measurements )	440 nm
Fu7 (SUN measurements )	936 nm
FK1 (SKY measurements)	1020 nm
FK2 (SKY measurements)	870 nm
FK3 (SKY measurements)	670 nm
FK4 (SKY measurements)	440 nm
FA1 (SKY measurements using sun collimator)	1020 nm
FA2 (SKY measurements using sun collimator)	870 nm
FA3 (SKY measurements using sun collimator)	670 nm
FA4 (SKY measurements using sun collimator)	440 nm

When transferring data from the photometer the number of filter is given with respect to its position in the filter wheel : the following table give the order of the filters in the filter wheel :

Filter number	Filter
1	1020 nm
2	870 nm (polarized)
3	670 nm
4	440 nm
5	870 nm (polarized)
6	870 nm
7	936 nm

8	870 nm (polarized)
---	--------------------

From the parameters of the photometer (PAR)

SKY/max                    yes or no

    If Yes

    MV: Maximum value (measure)

    if NO

    LV: Last value(measure),

SKY Cal                    yes or no

    If Yes

    LG : low gain

    If No

    HG : High gain

Symbol will be displayed in relation to your choice and depending on the type of measurements SUN or SKY:

### **SKY Measurements :**

Measurements from 1 to 4 ( 1020, 670, 440, 870) are made using Sun collimator, from 5 to 11 using Sky collimator.

Number	Filter	SKY-HG-MV	SKY HG LV	SKY-LG-MV	SKY-LG-LV
1	1020	A1	A1	A1	A1
2	670	A3	A3	A3	A2
3	440	A4	A4	A4	A3
4	870	A2	A2	A2	A4
5	1020	X1	@1	$\alpha$ 1	k1
6	polarized 870	X2	P1	$\pi$ 1	k2
7	670	X3	@3	$\alpha$ 3	k3
8	440	X4	@4	$\alpha$ 4	k4
9	polarized 870	X5	P2	$\pi$ 2	k5
10	870	X6	@2	$\alpha$ 2	k6
11	polarized 870	X8	P3	$\pi$ 3	k8
12	Temperature	T	T	T	T

### **SUN Measurements :**

Filter number	filter	SUN
1	1020	a1
2	870 (polarized)	p1
3	670	a3
4	440	a4
5	870 (polarized)	p2
6	870	a2
7	936	w1

8	870 (polarized)	p3
---	-----------------	----

**PPLAN :**

Scanning the vertical plan relative to the zenithal position of the sun.

Position (N-measure)	Display(first scan)	2 scan	3 scan	4 scan
-6° to -2° (1 to 7)	A1	A3	A4	A2
0° (8)	a1	a3	a4	a2
+2° to+6° (9-15)	A1	A3	A4	A2
6° to 150°(16 -40)	@ 1	@ 3	@ 4	@ 2

a : indicates to measurement made using Sun collimator at low gain  
a1 = 1020, a2 = 870nm , a3 = 670nm, a4 = 440nm.

A : indicates to measurement made using Sun collimator at high gain  
A1 = 1020, A2 = 870nm, A3 = 670nm, A4 = 440nm.

@ : indicates to measurement made using Sky collimator at high gain  
@1 = 1020, @2 = 870nm, @3 = 670nm, @4 = 440nm.

The following Table represents for a principal plane scenario the relative number of measurements, positions, and symbol of each measurement.

**(at the position 6° two measurements are made)**

Number	Position	1 Scan	2 Scan	3 Scan	4 Scan
1	-6.0	A1	A3	A4	A2
2	-5.0	A1	A3	A4	A2
3	-4.0	A1	A3	A4	A2
4	-3.5	A1	A3	A4	A2
5	-3.0	A1	A3	A4	A2
6	-2.5	A1	A3	A4	A2
7	-2.0	A1	A3	A4	A2
8	0	a1	a3	a4	a2
9	+2.0	A1	A3	A4	A2
10	+2.5	A1	A3	A4	A2
11	+3.0	A1	A3	A4	A2
12	+3.5	A1	A3	A4	A2
13	+4.0	A1	A3	A4	A2
14	+5.0	A1	A3	A4	A2
<b>15, 16</b>	<b>+6.0</b>	<b>A1,@1</b>	<b>A3,@3</b>	<b>A4,@4</b>	<b>A2,@2</b>
17	+8.0	@1	@3	@4	@2
18	+10.0	@1	@3	@4	@2
19	+12.0	@1	@3	@4	@2
20	+14.0	@1	@3	@4	@2

21	+16.0	@1	@3	@4	@2
22	+20.0	@1	@3	@4	@2
23	+25.0	@1	@3	@4	@2
24	+30.0	@1	@3	@4	@2
25	+35.0	@1	@3	@4	@2
26	+40.0	@1	@3	@4	@2
27	+45.0	@1	@3	@4	@2
28	+50.0	@1	@3	@4	@2
29	+55.0	@1	@3	@4	@2
30	+60.0	@1	@3	@4	@2
31	+65.0	@1	@3	@4	@2
32	+70.0	@1	@3	@4	@2
33	+80.0	@1	@3	@4	@2
34	+90.0	@1	@3	@4	@2
35	+100.0	@1	@3	@4	@2
36	+110.0	@1	@3	@4	@2
37	+120.0	@1	@3	@4	@2
38	+130.0	@1	@3	@4	@2
39	+140.0	@1	@3	@4	@2
40	+150.0	@1	@3	@4	@2
41	Temperature	T	T	T	T

**PP (Polarized Principal Plan) :**

P1, P2, P3 are the characters relatives to the three polarized 870nm filters.

Only one scan is realized from +95° to +265°, by step of 5° at each position three measurements are made one at each polarized filter.

**ALMUCANTAR :**

Scanning the horizontal plane relative to the azimuth position of the sun.

a : indicates to measurement made using Sun collimator at low gain

a1 = 1020, a2 = 870nm , a3 = 670nm, a4 = 440nm.

A : indicates to measurement made using Sun collimator at high gain

A1 = 1020, A2 = 870nm, A3 = 670nm, A4 = 440nm.

@ : indicates to measurement made using Sky collimator at high gain

@1 = 1020, @2 = 870nm, @3 = 670nm, @4 = 440nm.

Position (N-measure)	TYPE	Display(first scan)	2 scan	3 scan	4 scan
0° (1)	SUN-LG	a1	a3	a4	a2
-6° to +6° (2-15)	SUN-HG	A1	A3	A4	A2
+6° to 354°(16-62)	SKY-HG-LV	@1	@3	@4	@2
354°to366°(63-76)	SUN-HG	A1	A3	A4	A2

(at each of the positions 6° and 354° two measurements are made one in SUN- HG and the other SKY - HG)

	POSITION °	1 SCAN	2 SCAN	3 SCAN	4 SCAN
		1020 nm	670 nm	440 nm	870 nm
1	0.0	a1	a3	a4	a2
2	-6.0	A1	A3	A4	A2
3	-5.0	A1	A3	A4	A2
4	-4.0	A1	A3	A4	A2
5	-3.5	A1	A3	A4	A2
6	-3.0	A1	A3	A4	A2
7	-2.5	A1	A3	A4	A2
8	-2.0	A1	A3	A4	A2
9	+2.0	A1	A3	A4	A2
10	+2.5	A1	A3	A4	A2
11	+3.0	A1	A3	A4	A2
12	+3.5	A1	A3	A4	A2
13	+4.0	A1	A3	A4	A2
14	+5.0	A1	A3	A4	A2
<b>15, 16</b>	<b>+6.0</b>	<b>A1, @1</b>	<b>A3, @3</b>	<b>A4, @4</b>	<b>A2, @2</b>
17	+7.0	@1	@3	@4	@2
18	+8.0	@1	@3	@4	@2
19	+10.0	@1	@3	@4	@2
20	+12.0	@1	@3	@4	@2
21	+14.0	@1	@3	@4	@2
22	+16.0	@1	@3	@4	@2
23	+18.0	@1	@3	@4	@2
24	+20.0	@1	@3	@4	@2
25	+25.0	@1	@3	@4	@2
26	+30.0	@1	@3	@4	@2
27	+35.0	@1	@3	@4	@2
28	+40.0	@1	@3	@4	@2
29	+45.0	@1	@3	@4	@2
30	+50.0	@1	@3	@4	@2
31	+60.0	@1	@3	@4	@2
32	+70.0	@1	@3	@4	@2
33	+80.0	@1	@3	@4	@2
34	+90.0	@1	@3	@4	@2
35	+100.0	@1	@3	@4	@2
36	+120.0	@1	@3	@4	@2
37	+140.0	@1	@3	@4	@2
38	+160.0	@1	@3	@4	@2
39	+180.0	@1	@3	@4	@2
40	+200.0	@1	@3	@4	@2
41	+220.0	@1	@3	@4	@2
42	+240.0	@1	@3	@4	@2
43	+260.0	@1	@3	@4	@2
44	+270.0	@1	@3	@4	@2

45	+280.0	@1	@3	@4	@2
46	+290.0	@1	@3	@4	@2
47	+300.0	@1	@3	@4	@2
48	+310.0	@1	@3	@4	@2
49	+315.0	@1	@3	@4	@2
50	+320.0	@1	@3	@4	@2
51	+325.0	@1	@3	@4	@2
52	+330.0	@1	@3	@4	@2
53	+335.0	@1	@3	@4	@2
54	+340.0	@1	@3	@4	@2
55	+342.0	@1	@3	@4	@2
56	+344.0	@1	@3	@4	@2
57	+346.0	@1	@3	@4	@2
58	+348.0	@1	@3	@4	@2
59	+350.0	@1	@3	@4	@2
60	+352.0	@1	@3	@4	@2
61	+353.0	@1	@3	@4	@2
<b>62, 63</b>	<b>+354.0</b>	<b>@1, A1</b>	<b>@3, A3</b>	<b>@4, A4</b>	<b>@2, A2</b>
64	+355.0	A1	A3	A4	A2
65	+356.0	A1	A3	A4	A2
66	+356.5	A1	A3	A4	A2
67	+357.0	A1	A3	A4	A2
68	+357.5	A1	A3	A4	A2
69	+358.0	A1	A3	A4	A2
70	+362.0	A1	A3	A4	A2
71	+362.5	A1	A3	A4	A2
72	+363.0	A1	A3	A4	A2
73	+363.5	A1	A3	A4	A2
74	+364.0	A1	A3	A4	A2
75	+365.0	A1	A3	A4	A2
76	+366.0	A1	A3	A4	A2
77	Temperature	T	T	T	T



# DCP

## Transmitter Module

**VX1004/2 - CE 820**

## **I- Transmitter Module VX1004/2 - CE 820 :**

With the transmitter (DCP) there will be the following items

- Antenna.
- 12V/20A battery.
- HF cable.
- Battery cable (2 pin female connector).
- Solar panel.
- solar panel cable (2 pin female connector).
- Antenna elevation mount.
- Solar panel elevation mount.
- Photometer - Transmitter cable ( DB 9 connector and phone connector).
- Alkaline 9 V battery (inside the box but not connected)

The transmitter accepts data serial data from the photometer, a PC or any other serial programming device (host), then transmits that data over meteorological satellite..

### **II- Installation :**

Connections to the DCP :

- To the input ( Bat) connect the battery 12V/20A by the mean of the black cable with a 2 pins female connector
- To the input (PS) connect the solar Panel by the mean of the black cable with 2 pins female connector.
- Connect the DCP ( Input CE318) to the photometer (input DCP) by the mean of the white cable (DB9 - phone connector).
- RF Output connect the antenna by the mean of the coaxial cable.

**(Never try a transmission before connecting the antenna).**

#### **- option :**

9 V battery ( exist already inside the DCP) may be connected ( you have to open the box ), this battery may backup time and information in the event of main power loss. Obviously, this battery is inadequate to power the transmitter during a transmission.

### **III- Programming the Transmitter ( Self - timed transmission mode) :**

At Power up all configuration data is zeroed, the buffers are zeroed, the real time clock is also zeroed. Certain user parameters must be programmed before it will send any transmission, the photometer works only in the self - timed transmission mode but before self - timed transmission enabled, the following parameters must be initialized :

- Satellite address.
- DCP address.
- Preamble Type.
- Transmission Offset Time.
- Self - timed Interval.
- Real time clock initialized.

Form the main menu of the photometer

- Abbreviations : [G] for the green key.
- [W] for the white key.
- [Y] for the yellow key.
- [R] for the red key.

21 / 12 / 92	22 : 59
PW MAN SCN VIEW	

Press PW [G] for Password then

- Introduce the password : PW = 1
- [R] to increase.
- [Y] to decrease.

22 : 59 : 59	PW	0
Pass	Word	- +

Press [G] to get this menu

- RTN [G] : Return to the main menu.
- INI [W] : Memory initialization.
- DAT [Y] : Time setting for the photometer.
- CFG [R] : Configuration functions of the DCP.

22 : 59 : 59
RTN INI DAT CFG

Press CFG [R] to get into the configuration procedure :

Press PAR [W] for the photometer parameters :

22 : 59 : 59
RTN INFD DCP PAR

[G] to get this menu

- OK [G] : to leave.
- X [W] : for other parameter.
- [Y] or + [R] : to change parameter value.

Country	0
OK X	- +

Press X [W] several time to get DCP Transm :

- To active dumping data from the photometer to the DCP
- Press - [Y] or + [R].

DCP Transm	NO
OK X	- +

Press again X [W] to get :

If transmission interval period of the satellite is 1 hour introduce Yes otherwise introduce No for interval of 20 minutes (- [Y] or + [R]).

DCP Per 1 H			
OK	X	-	+

Press again X [W] to get DCP Load T :

Time (in minutes) at which the Photometer will dump data to the DCP, it is better to fix a dumping time 15 minutes before transmission.

DCP Load T			5
OK	X	-	+

Press - [Y] or + [R] : to change parameter value.

If you have a transmission interval of one hour the photometer will dump data once per hour, for 20 minutes interval the photometer will dump data twice per hour.

Example :

For 1 hour interval and transmission time HH:20:00, if you chose DCP Load T = 5, the photometer will dump data at HH:05:00.

For 20 minutes interval and transmission time HH:20:00, if you chose DCP Load T = 5, the photometer will dump data at HH:05:00 and at HH:25:00.

Press again X [W] to get

Maximum number of byte to be transmitted

Press - [Y] or + [R] to change value.

DCP max			560
OK	X	-	+

It is better to keep the number of bytes equal or less

than 610 for a one minute transmission window and 1250 for a two minute window.

Press OK [G] then Yes [R] to valid the modifications.

## Who to get into the configuration menu of the DCP?

### **IV- Reading Current Configuration of the DCP:**

Form the main menu of the photometer

- Abbreviations :    [G]    for the green key.  
                          [W]    for the white key.  
                          [Y]    for the yellow key.  
                          [R]    for the red key.

21 / 12 / 92	22 : 59
PW	MAN SCN VIEW

Press PW [G] for Password then

Introduce password : PW = 1  
                          [R] to increase.  
                          [Y] to decrease.

22 : 59 : 59	PW	0
Pass	Word	- +

Press [G] to get this menu

RTN [G] : Return to the main menu.  
INI [W] : Memory initialization.  
DAT [Y] : Time setting for the photometer.  
CFG [R] : Configuration functions of the DCP.

22 : 59 : 59
RTN INI DAT CFG

Choose CFG [R] to get into the configuration procedure :

Press [W] for INFD as INFormation about DCP

22 : 59 : 59
RTN INFD DCP PAR

Press [W] to scroll through the configuration menu.

The first screen gives photometer time (first line HH:MM:SS) and the DCP time (second line).

T PHOTO-	08: 50 : 20
time DCP-	08: 50 : 20

Press again [W]

Time to next transmission (HH:MM:SS)  
12 minutes and 20 seconds

Next Transmission
00 : 12 : 20

NO Transmission : The internal buffer of the DCP is empty, this happens after transmission until the buffer

Next Transmission
NO Transmission

is reloaded by the Photometer. The message will be replaced by time just after the DCP Load time fixed in the photometer parameters. If not this may be due to :

- The DCP is not active (transmission is not enabled)(see section-V).
- You did not active **DCP trans** from parameters of the photometer(see section III).

Press again [W]

Number of bytes that has been transferred from the photometer to the DCP.  
Press again [W]

Nb Bytes	560
----------	-----

Forward / reflected power of the last transmission  
Press again [W]

Power E/R	15/2
-----------	------

Number of data block available in the Photometer memory which has not been transmitted yet.  
Each block may contains from 21 up to 256 bytes.

NB EVT	021
--------	-----

Press again [W]

Identifications of the last 4 errors (Command-Error).  
Example : error 00-10  
Error = 10 : Low Battery.  
Press again [W]

1: 00-10	2 : 00-00
2: 00-00	4 : 00-00

Total number of errors  
Press [G] to return to the main menu  
Press [Y] to clear errors.

Total ERROR	000
RTN CLEAR	

The transmitter maintains a count of the total number of errors that have occurred, and a log of the last 4 errors. Error cods are defined as follows :

0	No Error
1	Command unknown
2	Pre-requisites not met
2	Time-out, Parameter bytes not received
4	Parameter value out of range
5	Checksum Error
6	Overrun Error
7	Noise Error
8	Framing Error
9	Synthesizer Error

For more details see the Vitel User's Manual (VX1004/2) of 26 May 1995.

## **V- Configuration Set-up of the Satellite Transmitter Modules DCP:**

To change any of the DCP parameters the Photometer must be in the manual mode (see Parameters of the photometer) and the DCP operating mode = OFF.

Form the main menu of the photometer

- Abbreviations : [G] for the green key.  
[W] for the white key.  
[Y] for the yellow key.  
[R] for the red key.

21 / 12 / 92	22 : 59
PW	MAN SCN VIEW

Chose PW [G] then introduce PW = 1  
to get the configurations menu  
[R] to increase.  
[Y] to decrease.

22 : 59 : 59	PW	0
Pass	Word	- +

Then press [G] to get this menu

RTN [G] : Return to the main menu.  
INI [W] : Memory initialization.  
DAT [Y] : Date and time setting.  
CFG [R] : Configuration functions of the DCP.

22 : 59 : 59
RTN INI DAT CFG

Choose CFG [R] to get into the configuration procedure :

22 : 59 : 59
RTN INI DAT CFG

Press DCP[Y] for DCP Set-up

22 : 59 : 59
RTN INFD DCP PAR

In the first line you have the photometer time.  
press VER [W] to know the version code of the DCP

22 : 59 : 59
RTN VER TIME SET

press TIME [Y] to adjust the DCP time.

**Press SET [R] for other parameters**

### **V- 1 Set-up DCP TIME**

**Prerequisites** : Self - Timed transmission and Random transmission disabled.

Press TIME [Y]

22 : 59 : 59
RTN VER TIME SET

Press RTN [G] to leave without changing the time  
Press EDIT [R] To set-up DCP time (HH:MM:SS)

DCP time	20 : 19 : 22
RTN	EDIT



Press Shift [W] to move cursor  
 Press [Y] or [R] to change the value  
 Press [G] to continue

DCP time	20 : 12 : 11
OK Shift	+ -

The clock will start only when you valid the modifications by Pressing [R].

DCP time	20 : 12 : 11
NO valid ?	YES

To cancel the modification press [G].

### **V-2 Load DCP Address :**

**Prerequisites :** Self - Timed transmission and Random transmission disabled.

The address is transferred to the transmitter as four bytes, at power up the address defaults to all zeroes.  
 Press [R] to change the address

DCP	00:00:00:00
RTN NEXT	EDIT

Press [W] to move cursor  
 Press [Y] or [R] to change the value  
 Press [G] to continue

DCP time	00:00:00:00
OK Shift	+ -

Example

To valid press [R]  
 press [G] to leave without modification.

DCP	FF:FF:FF:FF
NO Valid?	YES

### **V-2 Load Satellite Type :**

This command allows user to select either the GOES, GMS, or METEOSAT frequencies and formats. At power up the transmitter defaults to GOES.

**Prerequisites :** Self - Timed transmission and Random transmission disabled.

Press [R] to change the satellite type  
 Press [W] for other parameters  
 Press [G] to leave configuration procedure

Satellite	GOES
RTN NEXT	EDIT

If you choose [R]

Press [W] to move cursor  
 Press [Y] or [R] to change the value  
 Press [G] to continue

Satellite	GOES
OK Shift	+ -

Press [R]to valid  
 Press [G]to leave without modification.

Satellite		GOES
NO	Valid?	YES

#### **V-4 Load Self - Timed Transmit Channel Number :**

The satellite type selection must be made prior to entering the channel number, at power up channel number defaults to ZERO, and the satellite type to GOES.

If the Satellite type is selected as :

- GOES : valid channels are between 1 and 199.
- GMS : valid channels are 1 and 100
- METEOSAT : Regional channels from 1 to 33 must be entered as channels 34 through 66 (**Regional channel + 33**).

**Prerequisites** : Self - Timed transmission disabled.

Press [R] to change channel number  
 Press [W] move to other parameters  
 Press [G] to leave configuration procedure

Selfchn		000
RTN	NEXT	EDIT

If you choose [R]

Example : for Channel R22

Press [Y] or [R] to change the value

Press OK [G] to continue

Selfchn		55
OK		+ -

Press YES [R]to valid

Press NO [G] to leave without modification.

Selfchn		55
NO	Valid?	YES

#### **V-5 Load Preamble Type:**

This commands loads the preamble type for **self - timed** transmissions into the transmitter.

LONG preamble is required by older receiving equipment, most receiving equipment manufactured since 1982 can receive messages with the SHORT preamble.

- SHORT preamble consists of 0.5 seconds of pure carrier and 0.48 seconds of 1/0 clock prior to the transmission of the frame sync word.

- LONG preamble consists of 4.9 seconds of pure carrier and 2.4 seconds of 1/0 clock.

All random messages are required to use the SHORT preamble.

for GMS and METEOSAT defaults preamble is LONG.

**Prerequisites** : Self - Timed transmission and Random transmission disabled.

Press EDIT [R] to change preamble type  
 Press NEXT [W] move to other parameters  
 Press [G] to leave configuration procedure

Preamble		Short
RTN	NEXT	EDIT

If you choose [R]

Press [Y] or [R] to change the value  
Press OK [G] to continue

Preamble	LONG
OK	+ -

Press YES [R] to valid  
Press NO [G] to leave without modification.

Preamble	LONG	
NO	Valid?	YES

### **V-6 Load Self - Timed Transmit Interval**

The interval is specified in

Days: Hours: Minutes: Seconds

Days may be from 1 to 21, Hours from 0 to 22, Minutes from 0 to 59, Seconds from 0 to 59. For GOES transmit interval 1 hour, for METEOSAT 20 min.

The interval defaults to Zero at powerup.

**Prerequisites** : Self - Timed transmission disabled.

Press EDIT [R] to change Self - timed Transmit interval

Press NEXT [W] move to other parameters

Press RTN [G] to leave configuration procedure

If you choose [R]

SPer	DD:HH:MM:SS	
RTN	NEXT	EDIT

Press + [Y] or - [R] to change the value

Press Shift [W] to move cursor

Press OK [G] to continue

SPer	00:00:00:00	
OK	Shift	+ -

Example : For Meteosat the interval is 30 minutes while it is 1 hour for GOES.

For Meteosat you have to put

SPer	00:00:30:00	
NO	Valid?	YES

For GOES you have to put

SPer	00:01:00:00	
NO	Valid?	YES

Press YES [R] to valid  
 Press NO [G] to leave without modification.

### **V-7 Load Transmit Offset Time For Self - Timed Transmission**

Transmit offset time for Self - timed transmission refers to the time offset from midnight for the first transmission. This time is specified in

Hours: Minutes: Seconds

The offset time defaults to zero at powerup.

**Prerequisites** : Self - Timed transmission disabled.

Press NEXT [W] move to other parameters  
 Press RTN [G] to leave configuration procedure  
 Press EDIT [R] to change transmit Offset time  
 then :

T offset	00:00:00
RTN	NEXT EDIT

Press + [Y] or - [R] to change the value  
 Press Shift [W] to move cursor  
 Press OK [G] to continue

Toffset	00:00:00
OK	Shift + -

Press YES [R] to valid  
 Press NO [G] to leave without modification.

Toffset	00:00:00
NO	Valid? YES

### **V-8 Load Transmit Window Length**

The transmit Window may be either 1 or 2 minutes.  
 The default value at power up : 1 minute.

**Prerequisites** : Self - Timed transmission disabled.

Press [R] to change Window length.  
 Press [W] move to other parameters  
 Press [G] to leave configuration procedure  
 If you choose [R]

Window	1 Min
RTN	NEXT EDIT

Press [Y] or [R] to change the value  
 Press OK [G] to continue

Window	1 Min
OK	+ -

Press YES [R] to valid  
 Press NO [G] to leave without modification.

Window	1 Min
NO	Valid? YES

### V-9 Select Data Buffer :

This commands causes the transmitter to select either the self - timed buffer or Random data buffer. **The Photometer works only with self mode.**

#### **Prerequisites :**

To enable Self - Timed Transmissions the following parameters must be initialized :

- DCP address
- Preamble Type
- Self - Timed Channel
- Transmit offset interval
- Self - Timed Interval
- Self Real Time Clock

Press EDIT [R] to change buffer selection.  
 Press NEXT [W] move to other parameters  
 Press RTN [G] to leave configuration procedure

Buffsel		Self
RTN	NEXT	EDIT

If you choose [R]

Press + [Y] or - [R] to change the value  
 Press OK [G] to continue

Buffsel		Self
OK		+ -

Press YES [R] to valid  
 Press NO [G] to leave without modification.

Buffsel		Self
NO	Valid?	YES

### V-10 Operating Mode

This command causes the transmitter to enable Self - Timed and/or Random transmissions.

Press EDIT [R]

OpMode		OFF
RTN	NEXT	EDIT

NEXT [W] move to other parameters  
 RTN [G] to leave configuration procedure

Press + [Y] or - [R] to change parameter  
 OFF, self, or Both **you have to chose self.**  
 Press OK [G] to continue

OpMode		Self
OK		+ -

Press YES [R] to valid  
 Press NO [G] to leave without modification.

OpMode		self
NO	Valid?	YES

## V-11 Load Random Transmit Channel Number

**(Not used by the Photometer)**

This commands loads into the transmitter the channel number for random transmissions.

**Prerequisites** : Random transmission disabled.

Press EDIT [R] to change random channel number  
Press NEXT [W] move to other parameters  
Press RTN [G] to leave configuration procedure

Randchn		000
RTN	NEXT	EDIT

If you choose [R]

Press + [Y] or - [R] to change the value  
Press OK [G] to continue

Randhn		000
OK		+ -

Press YES [R] to valid  
Press NO [G] to leave without modification.

Selfchn		58
NO	Valid?	YES

## V-12 Load Random Transmit Interval

**(Not used by the photometer)**

The interval is specified by in  
Hours: Minutes: Seconds  
The interval defaults to zero at powerup.

**Prerequisites** : Random transmission disabled.

Press EDIT [R] to change Random Transmit interval  
Press NEXT [W] move to other parameters  
Press RTN [G] to leave configuration procedure

RandPer		00:00:00
RTN	NEXT	EDIT

If you choose [R]

Press + [Y] or - [R] to change the value  
Press Shift [W] to move cursor  
Press OK [G] to continue

RandPer		00:00:00
OK	Shift	+ -

Press YES [R] to valid  
Press NO [G] to leave without modification.

RandPer		00:00:00
NO	Valid?	YES

## **V-12 ERROR 11 :**

If you see at the display ERROR 11, this means that the photometer is unable to communicate with the DCP this may occurs :

- While trying to get in communication with the DCP during transmission. ( wait until the end of transmission)
- connection problem :
  - verify that the battery is connected to BAT input
  - verify the connection between the DCP and the photometer (white cable).

# MAINTENANCE OF THE MOTORIZED FRAME verification and adjustments of the parking position

**The verification has to be done at least one time a year  
It consists on a test and a greasing for each motorized axis  
An adjustment is also necessary if the test is not correct.**

**1 - VERIFICATION OF THE CORRECT POSITION OF THE DETECTOR .**

**Warning !** This test can be done only by the "PILOTE" and "ASTP" programs of the 4.3C last version.

The test can be done on the site using a table and an apparatus with at least the command box, the robot, and the charged battery (12V).

**1-1 Enter into the "TEST MODE 02"** ( see the corresponding chapter )

**1-2 Active the PARK scenario :** For activating park scenario just do the following instructions

1-2-1 Return to the main menu by selecting <b>SCN [Y]</b>	31 / 12 / 93 23 : 58 PW MAN SCN VIEW
1-2-2 Scenario label increment ( + ) : choose the park scenario by pushing <b>[R]</b> one time .	H 000 000 V000 000 RTN GO - + OFF
1-2-3 Choose <b>GO [B]</b> for starting the parking	H 000 000 V000 000 RTN GO - + PARK
<i>1-2-4 Screen displayed for short period while preparation of the action</i>	a c t i v i n g      P A R K
<i>1-2-5 The azimuth motion begins the search for its position of origin</i>	H 000 000 V000 000 FF      P A R K      ****
<i>1-2-6 The position of origin AZ has been found The zenith motion begins</i>	H 120 090 V000 000 FF      P A R K      ****
<i>1-2-7 The position of origin ZN has been found Results displayed for short period</i>	H 120 090 V122 093 FF      P A R K      ****



1-2-8 Return to the main menu

31 / 12 / 93	23 : 59
PW MAN SCN VIEW	

1-2-9 Select **SCN [Y]** for monitoring tests results

H 120	090	V122	093
RTN	GO	- +	OFF

The test can be started again initiating the sequence as in 1-2-2 .

### 1-3 Mechanical principle of the detection of the origin

A system with a cam, acting on the micro switch grain, defines for each revolution a reference which is considered as the rotation origin. For quick break switches type with hysteresis, the activation is produced by the motion of an index rigidly locked with the exit train of the moto reducer. ( fig. 1 )

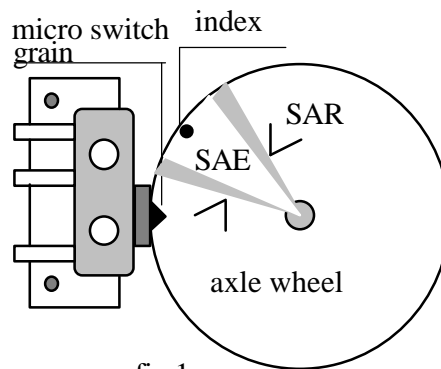

Because of the hysteresis, the engaging and relaxing points are angularly distant and symmetrically disposed by pair regarding to the diameter indexed according to the rotation direction.

The origin is the angular position resulting from the four points geometrical mean defined by the engagement and the relaxation for each rotation direction.

The experience shows that the origin is stable with a 3' precision given by a motor step (**PM**).

The angular sector defined by the two engaging points is named **SAE**.

The angular sector defined by the two relaxing points is named **SAR**.

**SAE** is smaller or equal to the **SAR**.

### 1-4 Origin search algorithm

The switches are twisted for presenting a **short-circuit (SC) outside the SAR** and an **open circuit (OC) inside the SAE**. For the intermediate sectors the contact state is a priori well-defined and depends on the precedent one.

**1-4-1 1st Case : If the contact initially presents a SC**, the axis position is presumed to be **outside the SAR**. Consequently **there is a rotation until a OC is obtained**, with a 180° maximum angle. After half a turn, the rotation direction changes and the search continues on 360°. If there is no success, a new rotation direction change occurs and the sequence begins

again, and finally the system gives up : in that case the final report for the concerned axis is **SAR 000-SAE 000**

In the contrary case, at the moment where the OC occurs and is confirmed during several **PM**, the system executes a scan (go and return) of the origin zone and find the **SAE** and **SAR** from angular coordinates of contact state changement points. Finally, the system puts the axis at the origin defined in 1-3.

**1-4-2 2nd Case : If the initial state of the contact is OC**, the axis position is presumed to be **outside the SAE**. The system tries to disengage it by a rotation of a 10° maximal angle, trying to reach the 1st case state.

As the **CC** is reached, the rotation direction is alternate and the search continues as described above.( 1st case )

If there is no success after a 10° disengagement test, the system orders the return to the initial position using an 10° inverse rotation. Finally the report is also **SAR 000-SAE 000**.

## 1-5 Results interpretation

The screen shown in 1-2-9 presents the test results on the first line :

H 120 090 V122 093
RTN GO - + OFF

becoming : **SAR = 120 , SAE = 90** for azimuth  
and **SAR = 122 , SAE = 93** for zenith

### 1-5-1 Right Running

According to the maximal course that can be applied to the micro switch without any damage, **SAE** has to be **lower than 6° or 120 PM** and is ideally between **80 et 90 PM**. Then **SAR** is **nominally greater than SAE** approximately of **30 PM**

When successive tests are done the **SA\* stability** has to be better than **± 3PM**.

For a well adjusted system, the difference **SAR-SAE** remains constant with a **1PM** precision. In contrary cases, the reducer has probably a reversal motion.

### 1-5-2 Positioning anomalies of the micro switch

A difference largely greater than 30 PM means that there is a push-button grain attrition which is probably due to a deficiency in greasing or a wrong adjustment.

An adjustment of the switch position must be done if **SAE < 70 or SAE > 100 PM**  
After adjustment and greasing,, its replacement is necessary if **SAR-SAE > 60PM**.

### 1-5-3 Anomalies of running

After an electrical parasitic event or an important contact rebound SAR can become very small and largely lower than SAE. Normally the system detects this anomaly and begins again the origin zone scan until a correct result is obtained. If not, the test must be done again. If the anomaly still exists or if it occurs too frequently during successive tests, then, the concerned switch must be replaced too.

#### 1-5-4 Disturbed states

Because of the origin search algorithm ( 1-4 ) : if the cable is disconnected ( 2nd Case ) - then, the concerned motor doesn't turn - the system renounces to adjust this axis after 2 seconds. If one of the 2 conductors assignable to the micro breaker is cut and if the contact to the pin is defective, the mechanical work execute 10° go and return and stops. In a same way, if the micro switch, damaged by a wrong positioning, remains always engaged

At the contrary, if the cable is in SC or if the micro breaker is never engaged, because it is too far from the came, the mechanical work execute 2 successive go and return on half a turn and on one turn and finds again its original position.

## 2 GREASING

### 2-1 Necessary material

- 1 allen key 2 ( for 2.5 CHC head screw )
- 1 syringe full of rolling grease ( orange )
- 1 bottle of joint grease ( white )
- Sticks with cotton

### 2-2 Zenith mechanical-work

#### 2-2 1 How laying out the cover

**Pick up** the 3 screws and **remove** the cover **with hands** by a rocking motion : it is rather difficult because the cover compresses an imperviousness joint. **Pay attention not to hurt it!** **Pick up** softly the cover and let it hanging on the cables extremities remaining attentive not to disconnect it from the connectors (normally hold with necklet). If this situation occurs the connectors have to be joined in pair **respecting the cable colors codes defined by pair.**

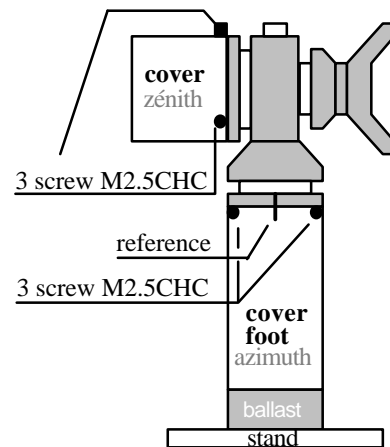

fig 2

### 2-2-2 Greasing

With the syringe, put a very small quantity of grease on the grain and on the index head ( fig. 3 ). Eventually turn the head by hand.

### 2-2-3 Reassembling

Take some joint grease with the stick, lay it on the torric joint periphery. Bring closer the cover, boxing up cables without pinching it. Put it on - holes standing in opposite, and the cable extremity being in the direction of the cover bottom. Engage the screws. Pay attention not to screw aslant. The cover positioning could be improve if the cover is turned and brought nearer the plummer-block. Clamp it softly with the alène key.

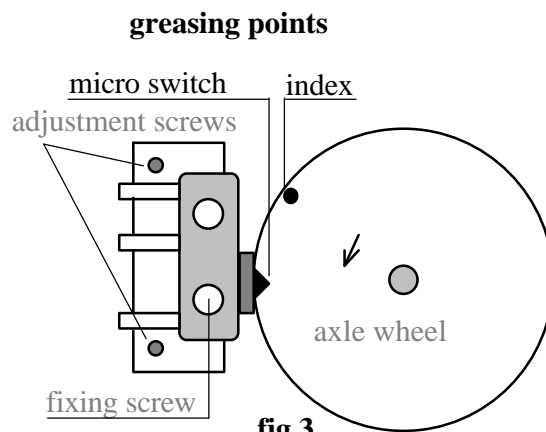

## 2-3 Azimuth mechanical-work

### 2-3 1 How laying out the cover

With a deletable pencil, trace a mark astride the foot and the plummer-block of the azimuth mechanical-work ( fig. 2), and proceed as in 2-2-1. Lay down the mechanical-work balanced on its foot, always hanging it.

### 2-3-2 Greasing

Proceed as the zenith part: 2-2-2

### 2-3-3 Reassembling

Proceed as the zenith part 2-2-3, the two marks have to be in coincidence

## 3 ADJUSTMENT OF THE MICRO SWITCHES POSITIONING

The adjustment of the micro switches positioning consists in bringing it closer or in moving it away from the wheel for obtaining correct test results. The adjustment must be done axis by axis, one by time and only if the result of the initial test for this axis is not correct. Disconnect the cable of the one which is not concerned.

### 3-1 Necessary material

UPPER VIEW ( TRANSPARENT PLATE )

- 1 alêne key (size 2)
- 1 screw-driver with flat strip (size 3)

### 3-2 Adjustment

#### 3-2-1 Simple adjustment

**Lay out** the cover ( see above 2-2-1 ).

**Turning** the head, **bring** the index **nearer** the grain by hand, in front of it, as shown in fig. 4. **Loosen** a few the adjustment screws with the alêne key. **If SAE < 70, bring** the micro breaker **closer** to the index, patting on the cale with the screw-driver sleeve. **If SAE > 100, remove it** pushing the cale with the screw-driver strip, taking one of the pillars as a support ( see details fig 5).

**Screw up** one of the adjustment screws and start the test. **Proceed** by successive approaches until a correct result is obtained, (  $80 < \text{SAE} < 90^1$  ). **Clamp** the adjustment screws et **replace** the cover.

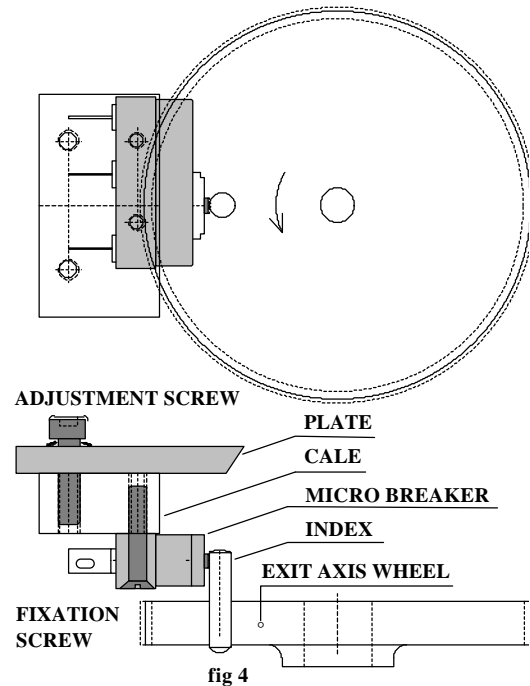

#### 3-2-2 Complete adjustment

If the result can not be obtained in the adjustment latitude given by the  $\pm 0.15$  mm free motion, **lay out** the breaker. **Remove** the two adjustment screws; **extract** the set cale + breaker, making it slip on the plate, then **turn it over** to make the fixing screws visible. **Loosen** the screws, giving to the screw nearest the grain 1 turn and to the other a 1/4 one. **Make** the breaker **swivel** a very few around the last one, in regards of the cale, in the appropriate direction. **Clamp<sup>2</sup>** the fixing screws ; **reingage** the adjustment screws **without clamping** them, and **execute** the simple adjustment **again**. If necessary doing again the complete adjustment, then the simple adjustment until good results are obtained.

If the micro switch is too far, the system can not find the origin more and orders go and return on half a turn and on one turn ( see 1-4 ). **Do** the complete adjustment again but, **make** the breaker **pivot some more**, a 0.3 mm pivot is a minimum in the direction that make it closer to the index. If the free motion is not sufficient, **loosen some more** the screw used as a pivot and apply a translation motion to the micro switch.

## 4 REPLACEMENT OF A MICRO SWITCH

<sup>1</sup>**Warning!** if  $\text{SAE} > 130$  don't execute the test before aving done the new adjustment

<sup>2</sup> The breaker body is made of Bakelite. It would split under a too strong clamping

The micro switch must be replaced if results have allowed to discover something wrong with the works(cf. 1-5-2 et 1-5-3 ) or, after an observation with lenses, if its grain appeared very worn ( the fig. 6 shows a new 10 times magnified micro switch grain ). A certain worn degree is bearable (on its half height). This is illustrated by the raise of the difference between SAR and SAE.



fig 5

#### 4-1 Necessary material

- 1 alêne key (size 2)
- 1 screw-driver with flat strip (size 3)
- 1 soldering copper (30 W max.)
- 1 scalpel
- 0.5mm welding with remover core
- thermoretractable sheath
- sticks with cotton
- solvent ( dichloréthane )
- adhesive ribbon (polyamide)

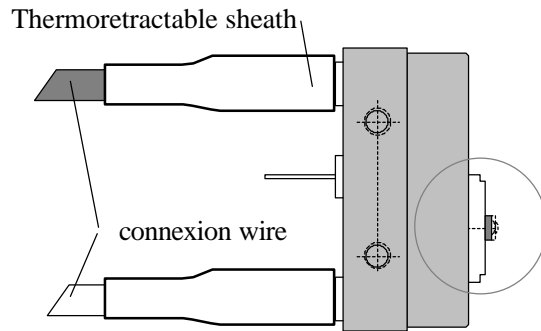

fig. 6

##### 4-1-1 Cover disassembling

**Lay out** the cover (cf. 2-2-1 ou 2-3-1 ). **Disassemble** the cale which hangs on the micro switch (cf. 3-2-2 ). **Turn over** the set, **loosen** the screws M2, **separate** and **turn over again**, the micro switch which hangs on its cables extremities appears as shown on the fig. 6. With the scalpel, **split** the thermoretractable sheath sections. **Make them slip** to see the welding. **Unsolder** and **extract** the two connection wires. **Take off** the sheathes

##### 4-1-2 Assembling of a new micro breaker

**Cut** two 1,5 mm long sections of thermoretractable sheath. **Thread** them on each wire by **pushing** them at least 3 cm away from the uncovered wire extremities. **Introduce** the wire in the thimble represented in the fig. 7. **By giving** the wire a right torsion, the micro breaker sustains by itself. **Do** the solders. **Clean** the resin residues with the stick impregnated of solvent. **Let slip** the sheathes by completely covering the thimbles

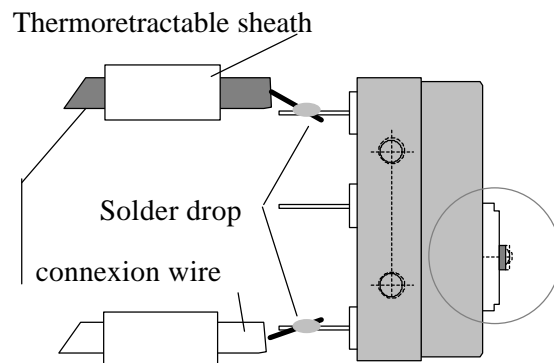
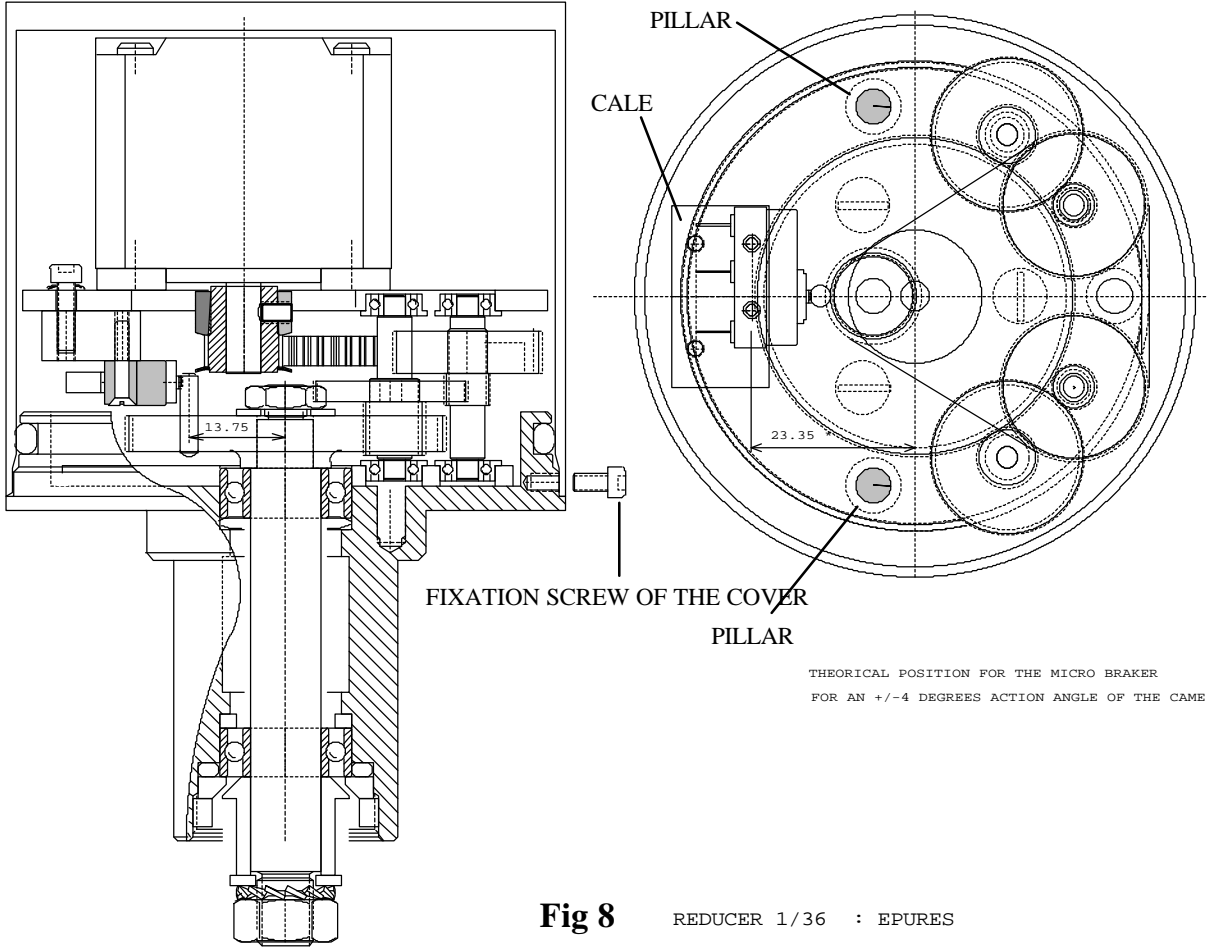

fig. 7

**Retract** the sheathes with a heat source, or better with a hot-air gun ,or a hair-drier, and as a last solution the soldering copper pane covered by adhesive ribbon. In that case slip the

pane along and around the sheath until the appearance of the fig. 6 is obtained. **Reassemble** the micro switch on its cale without clamping the screws M2. **Remain attentive to the direction.** Set all parts and proceed to the complete adjustment ( 3-2-2).  
 The following page shows two detailed views of the assembled reducer.



**Fig 8** REDUCER 1/36 : EPURES